

Drive Technology with Inverted Tooth Chains from Rexroth

Inverted tooth chains from Rexroth for demanding drive applications

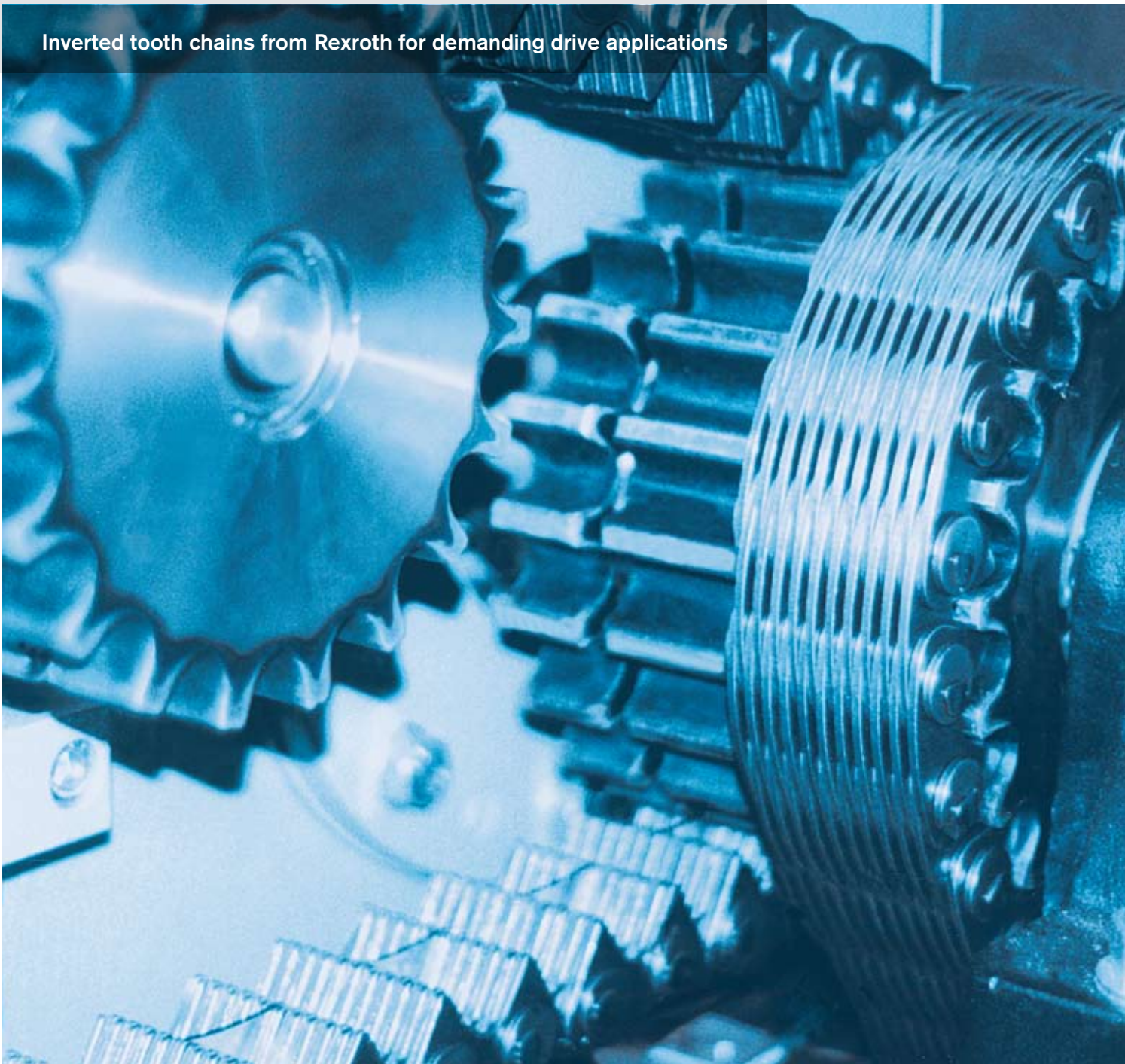

Fast. Precise. Silent



Rexroth tooth chain drives

The inverted tooth chain's ability to **transfer high loads** in small spaces ensures that multiple drive applications are optimally implemented. The perfectly adjusted geometry of inverted tooth chain and sprocket engagement helps to minimize the intensity of chain link impact, thus illustrating the drive element's well-earned reputation of **silent running**.

This is especially apparent for **higher velocities** up to **50 m/s**, achieved as a result of the characteristic 2-part rolling pivot joint and special link plate forms found in Rexroth tooth chain drives. Both profile pins of the rolling pivot joint roll against one another whenever the joint moves and sliding friction is minimized. This guarantees substantially reduced wear and **increased service life**.

Inverted tooth chain drives from Rexroth—Full-strength application solutions

In conjunction with the low impact typical for tooth chains, this drive solution is distinguished by **extremely smooth, even, and precise running**. As opposed to e.g. roller chains, wear is evenly distributed over all joints and all pitches are increased at the same rate. As a result, all inverted tooth chain links always scribe one common pitch circle. The interlocking power transmission between the inverted tooth chain and the sprocket is **slip-free**, and **no pre-tensioning** is necessary. The **variable construction** of the inverted tooth chains makes any required chain width and length possible. Especially in tight spaces or with large shaft center distances, this allows for a solution optimized to the application and the actual load in question. Thanks to the use of premium materials and production processes, tooth chains can also be used in harsh ambient conditions, at **high temperatures**, or with **aggressive chemicals**.

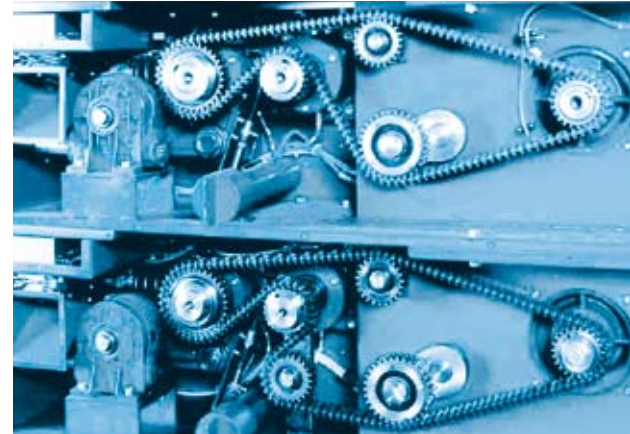

Substantially extended application life, minimized downtime—Rexroth chain drives assure cost-effective use.

The inverted tooth chain's design: A multitude of strengths

The inverted tooth chain is a cohesive network of sturdy links. Depending on the required length and width, it is made of a variety of link plates and profile pins. The result: a powerful and flexible chain drive that can be perfectly adapted to the specific task at hand.



The inverted tooth chain is composed of:

- Toothed plates
- Guide plates
- Rolling pivot joint—consists of 2 profile pins
- Rivet washers

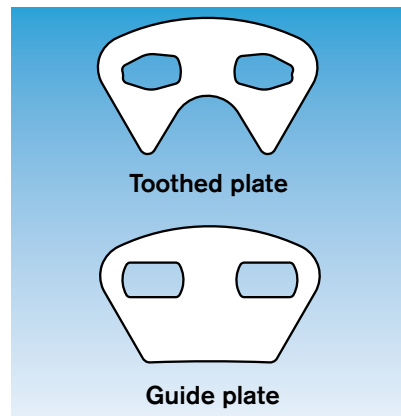

Inverted tooth chain construction

The image shows an HPC inverted tooth chain with a center guide.

A chain is made up of a certain number of links which are also named as pitches.

The chain length—meaning the number of chain links—depends on the number of teeth on the sprocket and the shaft center distance.

Depending on the chain width, each link will have a certain number of link plates arranged in a staggered configuration from link to link. These links are connected to one another by the rolling pivot joint.

Force and motion are transmitted via the toothed plates. Each link plate is provided with two joint bores to accommodate the rolling pivot joint. The rolling pivot joint is composed of two profile pins that are designed according to the chain type. Both pins are held captive within the plates. When a joint moves—as the chain enters and exits the sprocket—the two profile pins roll against each other. The remaining sliding friction is minimized.

Types of standard guides

Guide plates prevent the inverted tooth chain from drifting sideways on the sprockets. The illustration of an inverted tooth chain with a center guide shows the guide plates located in the center. The wheel toothing also features a profiled guideway to support the guide plates. The lateral play within the groove corresponds to link plate thickness for standard sprockets. In the inverted tooth chain shown aside, the guide plates are located on the outer sides of the chain. The side guide is particularly favored for narrow widths since the toothing is not weakened by the guideway. Here, the sprocket runs between the

guide plates and the minimum play needs to be adjusted to the minimum thickness of the toothed link plate package. Guide plates can also be arranged in several rows in an inverted tooth chain as a multiple center guide, meaning the construction is either a multiple center guide or a combined center/side guide. These modifications are used to provide better support in drives with vertical shafts, for example. In this case, additional support flanges on the sprocket are not required.

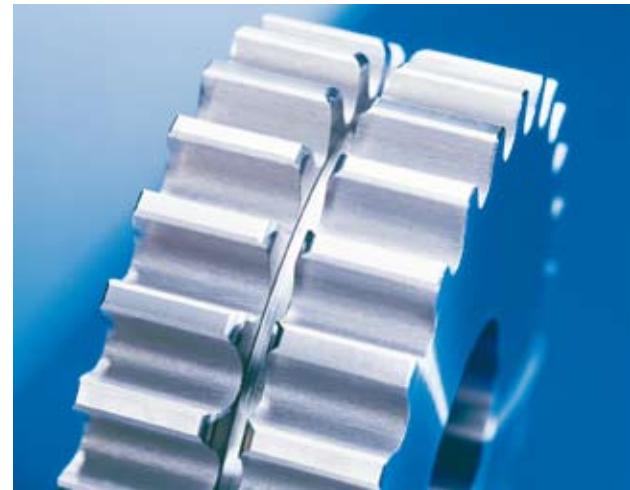

HPC sprocket with a center guide

Guide plates generally do not contribute to power transmission. Special guide plates designed as reinforcement plates can be used in slow-running, high-performance drives suffering a limited amount of space. In addition to their guide functions, these link plates also contribute to power transmission. Please contact us if you would like more details on this option.

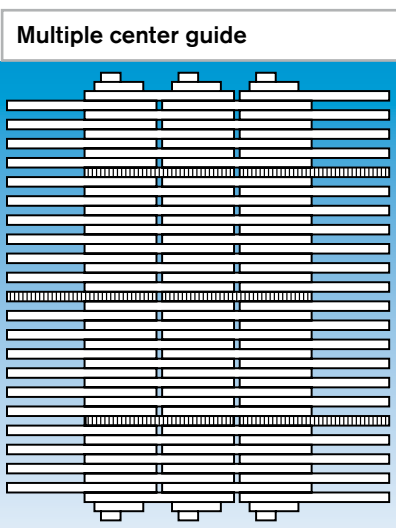
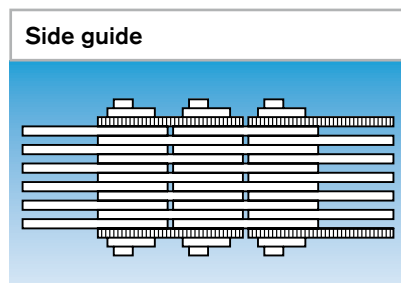
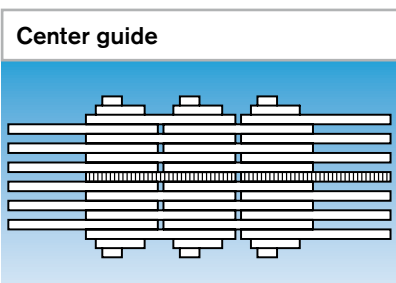

Drive chain with reinforcement plates

Inverted tooth chains and sprockets in perfect harmony

No room for false teeth.

Properly machined sprockets are essential to the inverted tooth chain's safe operation and long service life.

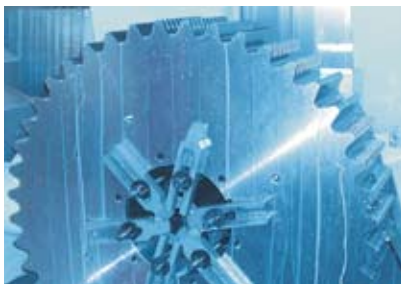

Using sprockets from other manufacturers invalidates the inverted tooth chain warranty.

The signature involute-toothing guarantees the quietest running possible of the tooth chain drive. If quiet running is a priority, wheels with higher numbers of teeth are preferred for higher speeds.

When determining the number of teeth, the outside space required—including the applied chain—and the permissible sprocket bore needs to be taken into account in addition to the minimum number of teeth for the respective type.

The tip diameters specified in the tables on the relevant type pages apply to wrap drives only. Using inverted tooth chains without wrap requires specially-toothed wheels.

Sprockets can be ordered ready for installation and manufactured according to the customer's specifications. Usually, C45 steel sprockets with hardened tooth flanks are used or cast-iron sprockets from GG or GGG.

An uneven amount of teeth should be preferable especially for cast-iron sprockets.

Other metallic and non-metallic materials are also possible.

The wheel width depends on the inverted tooth chain width and guide type.

Special types

2-part sprockets can be delivered for later installation on through shafts.

The toothing can be milled directly in a shaft.

Flanges or feed disks

The sprocket guideway is done away with on special inverted tooth chains lacking guide plates. The sprockets can be equipped with flanges on both sides to act as a lateral guide for the inverted tooth chain.

Conditions are similar for drives with vertical shafts. A feed disk with an enlarged diameter is mounted at the bottom of the sprockets. The tooth chain is supported by the protruding ring surface and relieves the guide plates from the chain's weight.



The secret's in the technology

Classic wrap operation? Counter-running drive shafts? Individual drive systems? With their special design, Rexroth inverted tooth chains offer a variety of unique product characteristics.

Runs like a whisper

The skillful reduction of chain link impact is one of the basic reasons behind the exemplary smooth running and lack of noise. The intensity of the impact is the result

of the chain link mass and the speed of impact. The equivalent characteristic values of Rexroth inverted tooth chains are significantly lower than those of other drive types.

Noise levels compared to other drives

At 24 m/s

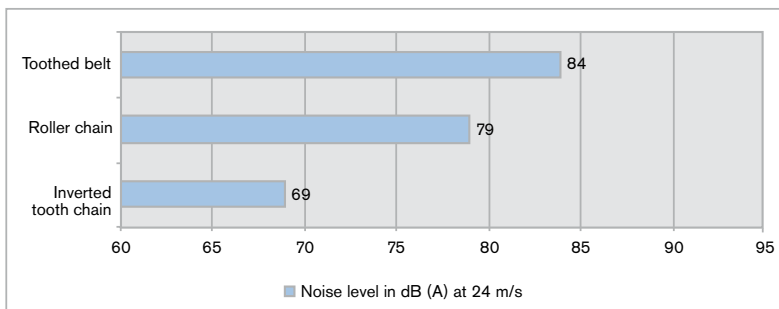

At 48 m/s

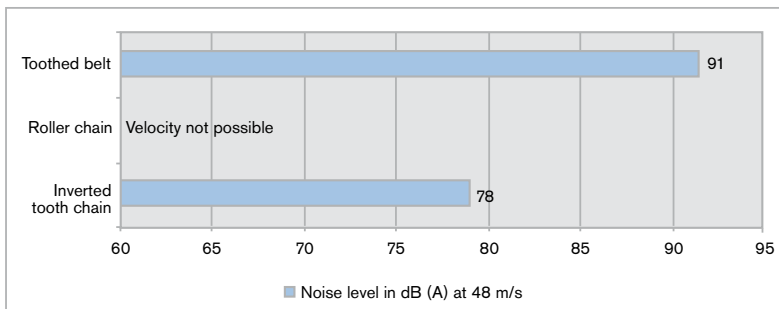

Inverted tooth chain

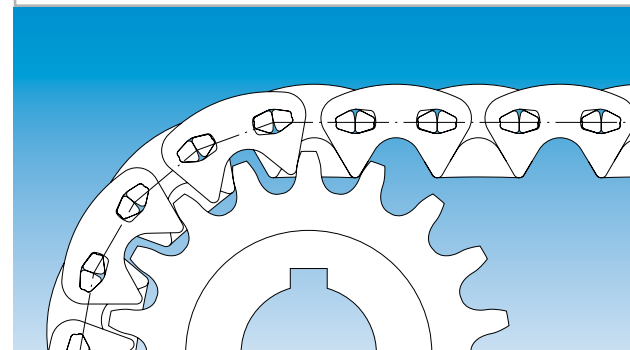

Roller chain

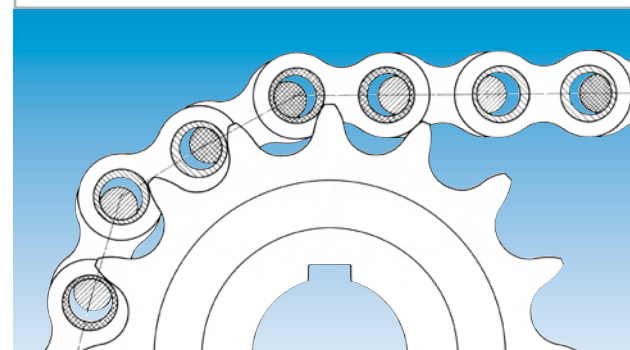

Engineering advantages compared to roller chains

The pictures reveal the fundamental difference of wear elongation during operation. Roller chains consist of outer and inner links which are subjected to varying wear and tear. Inner links experience a different degree of wear than outer links. Therefore outer links describe a larger pitch circle. This causes the chain to move jerkily and also places uneven stress on the sprocket teeth. At the same time, vibrations result in a noise level increase.

Advantages of inverted tooth chains over toothed belts ...

Example: Winder velocity profile

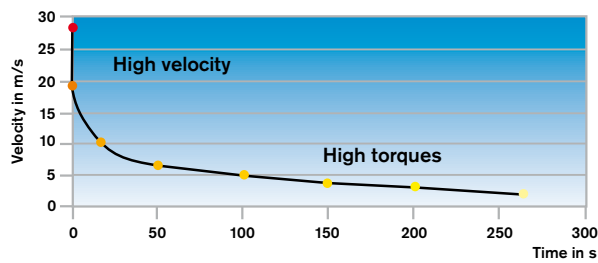

Even with varying loads, an inverted tooth chain is the optimum solution.

Using inverted tooth chains avoids the consequences of faulty belt tensioning:

- Danger of skipping
- Greatly reduced service life
- Higher temperatures resulting from friction
- Increased energy consumption
- Less efficiency
- Damage to permanently lubricated bearing and integrated measuring systems (among others)

Overlapping pre-tensioning and working load leads to higher belt loads, wider belts, and thus noise problems at higher speeds.

Variable loads—where belts start to jump, the inverted tooth chain can hold court

Within their maximum carrying capacities, inverted tooth chains with a particular drive can transfer a variety of loads (torques, speeds) with the same quality. This applies especially to winder and universal spindle drives. Toothed belts can be optimally engaged only within a small load range since only the data from one operating point are used to determine the pre-tensioning. This leads to considerable problems in drives whose loads are frequently changing or whose use cannot be predicted by the customer.

For most of the time—or even generally—the belt drive is either tensioned too little or too much and is thus subjected to stronger wear resulting from flank friction. This is particularly true in belt disks with reduced tooth flank backlash, the so-called zero-gap meshing.

Static load

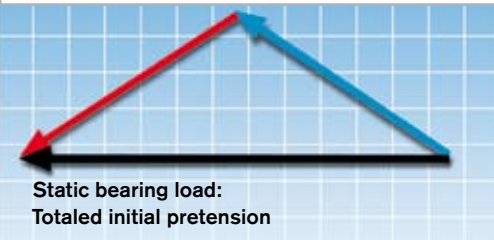

Dynamic load

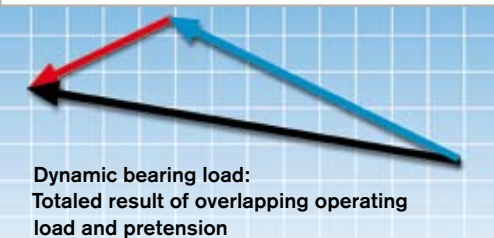

Pre-tensioning—do bearings really have to suffer?

Inverted tooth chains generally run without pre-tensioning, eliminating a large part of the bearing load. Toothed belt drives sometimes need to be pre-tensioned with more than the drive load component to ensure safe transmission of the operating load. This is true to an even greater extent for Poly V and flat belt drives.

The pre-tensioning force is determined based on normal, dry conditions. Any reduction of the friction coefficient through ambient influences, for example, must also be compensated for on toothed belts by further increasing the pre-tensioning.

More advantages of Rexroth inverted tooth chains over belts ...

- More resistant to chemicals, especially when cooling lubricants are used
- Simple assembly thanks to the possibilities of pin locks associated with correspondingly short downtimes or the lack of extra construction
- Reduced sensitivity to temperatures > 85°C and extremes in humidity, e.g. material does not swell and the tensile member does not shrink when moisture is absorbed

... and over other drive solutions

Heating things up

Throughout many years of development work, Rexroth has consistently been able to substantially improve inverted tooth chain performance in high-temperature drive applications. In conjunction with the original Rexroth rolling pivot joint, even our standard drives can be continuously operated in ambient temperatures up to 120°C—and are thus clearly better than most other drive elements. Additionally, our HAT (High Ambient Temperature) inverted tooth chains and sprockets can be used with heat-resistant lubricants at temperatures of up to 200°C without any noticeable increase in wear.

Working temperature compared to other drives

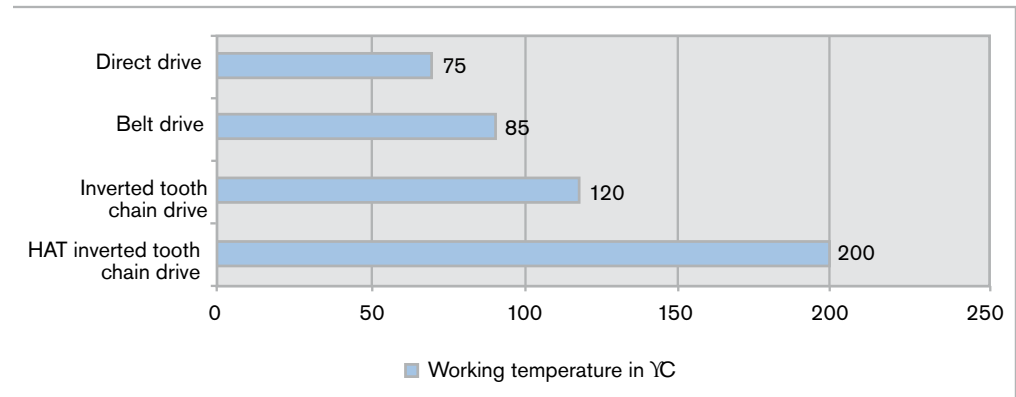

More assets at a glance: Advantages of Rexroth inverted tooth drive chains over ...

... other steel pintle chains

- Very high maximum speed
- Low and uniform wear
- Low running noise
- Good meshing conditions
- Low wear even with standard sprockets
- Highly flexible width
- Smooth running, not susceptible to vibration
- High efficiency
- Consistent, high quality

... gear wheels/gear boxes

- Low cost for wide shaft center distances
- Meshing unaffected by fluctuations in temperature
- Quiet at every operating point
- Zero tooth flank backlash
- High tolerances for shaft arrangement
- Possible to combine rotatory and linear motion
- Good self-damping
- Highly efficient at every operating point
- Moderate costs for special solutions

Inverted tooth chains from Rexroth—the benchmark for wrap drives.

Rexroth has the right drive concept for every application

Rexroth—the art of optimization

Faster, stronger, quieter.
Constant progress is the only way to reach this goal.
 The development of the very first inverted tooth chain to the

original type HPC from Rexroth is the result of many years of effort put in by a motivated team of technicians and engineers. All to your advantage!

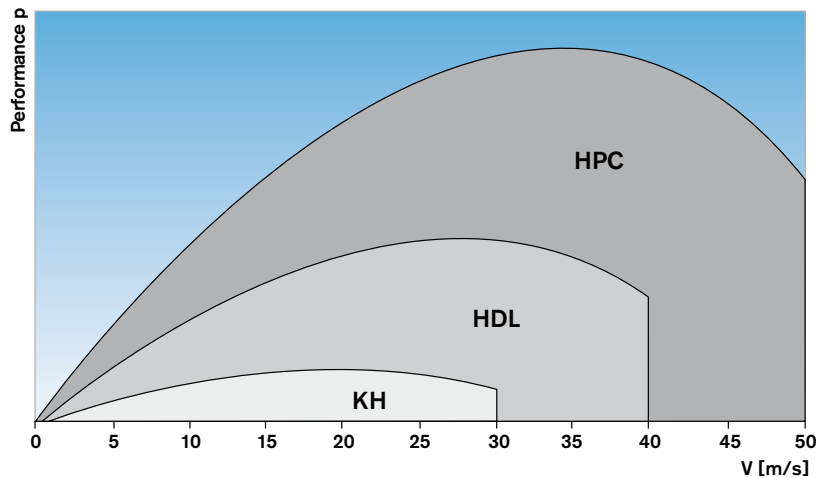

Biflex—flexible to both sides

Our invention

For performance and precision, fully symmetrical link plates provide equal drive on both sides and in both directions.

Problems with counter-running shafts, S-shaped wraps, or space-saving tensioning methods can be eliminated with Rexroth inverted tooth drive chains.



Individual—ready to meet your requirements

The maximum flexibility of the inverted tooth chain drive system allows it to be adapted easily to the most diverse requirements. We can supply your application

solution—from individual special link plates to complete specialized inverted tooth chains.



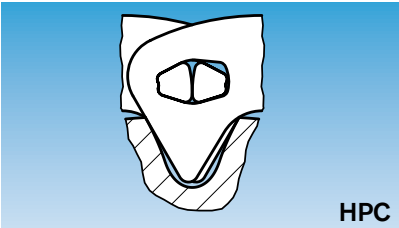

HPC

Type designation: HPC
 Available pitches: 3/8", 1/2", 3/4", 1", 1 1/2"
 Minimum number of teeth on the sprockets: 3/8" to 3/4" 17 teeth
 1", 1 1/2" 19 teeth
 from 1 m/s ≥ 23 teeth
 Max. velocity: up to 50 m/s

Pages 12 – 15

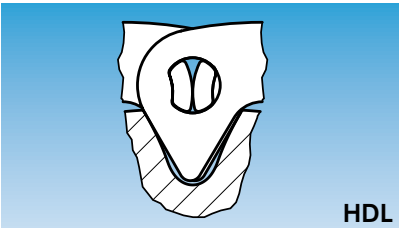

HDL

Type designation: HDL
 Available pitches: 3/8", 1/2", 3/4", 1"
 Minimum number of teeth on the sprockets: 17 teeth
 from 1 m/s 23 teeth
 Max. velocity: up to 40 m/s

Pages 24, 26 – 27



KH

Type designation: KH
 Available pitches: 5/16", 3/8", 1/2", 5/8", 3/4",
 1", 1 1/2", 2", 2 1/2"
 Minimum number of teeth on the sprockets: 5/16" to 3/4" 13 teeth
 from 1" 15 teeth
 Max. velocity: 5/16" to 3/4" up to 30 m/s
 from 1" up to 25 m/s

Pages 25, 28 – 29

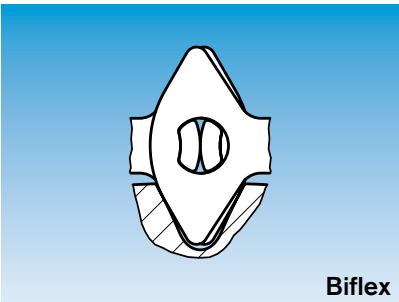

Biflex

Type designation: BIZ
 Available pitches: 3/8", 1/2", 3/4", 1"
 Minimum number of teeth on the sprockets: 3/8", 1/2", 3/4" 18 teeth
 1" 19 teeth
 ≥ 23 teeth preferred
 Max. velocity: up to 40 m/s

Pages 16 – 19

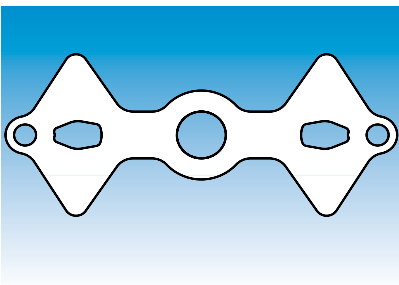

Tradition meets innovation

Special chains of all types and pitches are individually adapted to the requirements specified. Using the latest technology and expertise acquired from over 100 years of experience, we are in the prime position to develop and produce a configuration perfect for your needs.

Pages 20 – 23

HPC inverted tooth chain drives

State of the art. The most powerful type of Rexroth inverted tooth chains sets new standards for wrap drives. Faster, quieter, and more precise than any other inverted tooth chain type before, the latest generation of inverted tooth drive chains with rolling pivot joint meets the highest demands.



The original: the HPC inverted tooth chain from Rexroth

Enhancements made to the proven HDL range unite the familiar and outstanding characteristics with new, extra advantages.

- Improved quiet running and low noise
- Low-friction rolling pivot joint with the optimum efficiency
- Higher load capacity and narrower inverted tooth chain width
- More resistant to wear and minimized elongation
- Inverted tooth chain velocities up to 50 m/s

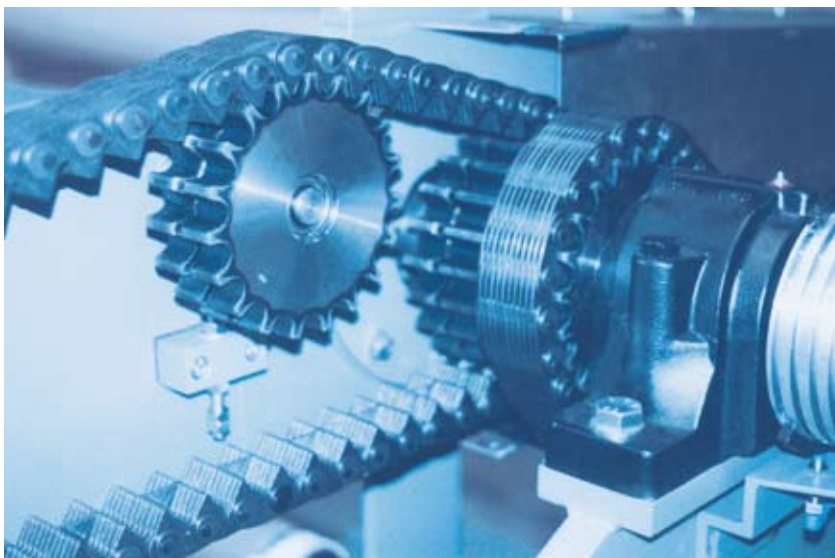

Stronger. Faster. Quieter

Over 60% more powerful than before.

- Higher dynamic rigidity, apparent on the eye and back cross section reinforcements
- Wedge-shaped joint profiles ensure a play-free position in the link plate bore and prevent self-movement that increases wear
- Compact cross section increases the joint's resistance to shearing and bending

Calculation formulas

$$P = \frac{M \cdot n}{9550}$$

$$v = \frac{Z \cdot p \cdot n}{60000} \leq 50 \text{ m/s}$$

With:

P = power in kW
M = torque in Nm
n = speed in r.p.m.
v = velocity in m/s
Z = number of teeth
p = pitch in mm

Note: Torque M and speed n must refer to the same sprocket with the number of teeth Z.

The impact factor must be adjusted to the actual torque in case of maximum speed. In general, a value of k = 1 is sufficient, deviating from the start-up behavior.

Optimized link plate form

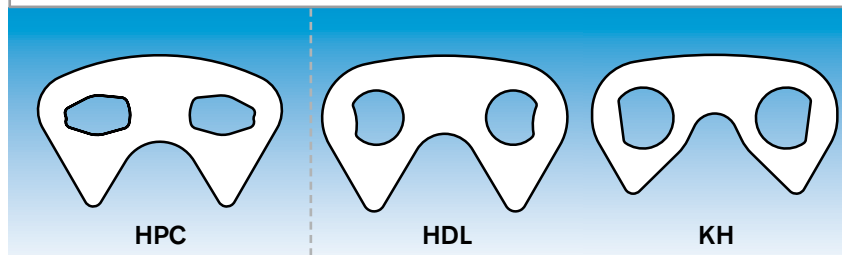

Optimized joint kinematics

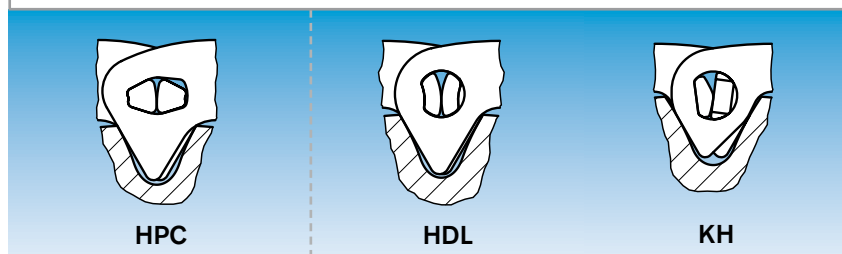

Step 1:

$$F_{\text{Berf}}^* \geq \frac{P \cdot k}{v} \cdot S_{\text{min}}$$

Step 2:

$$F_{\text{Berf}} \geq \left(\frac{P \cdot k}{v} + G \cdot v^2 \cdot 10^{-3} \right) \cdot S_{\text{min}}$$

With:

F_{Berf} = design breaking load in kN
P = power in kW
k = impact factor according to table
v = velocity in m/s
G = inverted tooth chain weight in kg/m
 S_{min} = type/application-dependent safety coefficient HPC = 8...10

Design impact factor values

Load	Drive motors		
	Soft startup drive	Three-phase current motor	Piston motor
Even	1,0	1,2	1,5
Medium impacts	1,3	1,5	2,0
Heavy impacts	≥ 1,7	≥ 2,0	≥ 2,5

How to calculate the required design breaking load:

1. Initial calculation according to step 1.
2. Select an inverted tooth chain from the table on page 14.
3. Recalculate according to step 2 and select again if necessary.

HPC inverted tooth chains

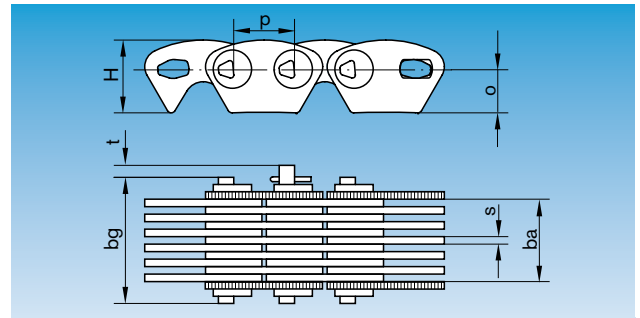
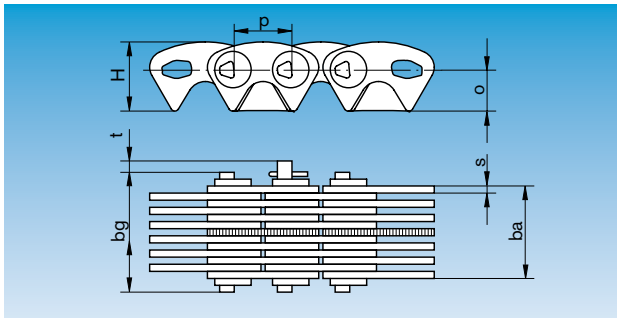

Pitch p	Designation no.	RZ	Nominal width b_n	Working width b_a	Total width b_g	Design breaking load	Weight [kg/m]	Sprocket width b	H	o	s	t
3/8" = 9,525 mm	HPC 015 A	10	15	12,5	19,9	25,4	1,0	11,5	11,3	6,8	1,5	2,0
	HPC 020 A	13	20	17,2	24,5	30,1	1,2	16,0				
	HPC 025	17	25	26,6	30,8	39,3	1,5	30,0				
	HPC 030	21	30	32,9	37,1	48,6	1,8	35,0				
	HPC 040	25	40	39,1	43,3	57,9	2,2	45,0				
	HPC 050	33	50	51,6	55,8	76,4	2,9	55,0				
1/2" = 12,7 mm	HPC 065	41	65	64,2	68,4	94,9	3,6	70,0				
	HPC 320 A	13	20	17,2	26,3	34,1	1,6	16,0	15,2	9,0	1,5	2,5
	HPC 325	17	25	26,6	32,6	52,7	2,0	30,0				
	HPC 330	21	30	32,9	38,9	65,1	2,4	35,0				
	HPC 350	33	50	51,6	57,6	102,3	3,8	55,0				
	HPC 375	49	75	76,7	82,7	152,0	5,6	80,0				
HPC 3100	65	100	101,7	107,7	201,6	7,5	105,0					
3/4" = 19,05 mm	HPC 3125	81	125	126,8	132,8	251,3	9,3	130,0				
	HPC 525	13	25	27,0	34,0	80,1	3,0	30,0	22,5	13,5	2,0	3,5
	HPC 540	21	40	43,7	50,7	129,4	4,9	50,0				
	HPC 550	25	50	52,0	59,0	154,0	5,8	55,0				
	HPC 585	41	85	85,3	92,3	252,6	9,5	90,0				
	HPC 5100	49	100	101,9	108,9	301,9	11,4	105,0				
HPC 5125	61	125	126,9	133,9	375,9	14,1	130,0					
1" = 25,4 mm	HPC 5150	73	150	151,8	158,8	449,8	16,9	155,0				
	HPC 5200	97	200	201,8	208,8	597,7	22,5	205,0				
	HPC 640	13	40	40,2	48,2	152,4	6,0	45,0	30,0	18,0	3,0	4,0
	HPC 650	17	50	52,6	60,6	199,4	7,9	55,0				
	HPC 665	21	65	65,0	73,0	246,3	9,7	70,0				
	HPC 675	25	75	77,4	85,4	293,2	11,6	80,0				
HPC 6100	33	100	102,1	110,1	387,0	15,3	105,0					
HPC 6125	41	125	126,9	134,9	480,9	19,0	130,0					
1 1/2" = 38,1 mm	HPC 6150	49	150	151,7	159,7	574,7	22,7	155,0				
	HPC 6200	65	200	201,2	209,2	762,4	30,1	205,0				
	HPC 850	17	50	52,8	64,8	303,4	11,8	60,0	45,0	27,0	3,0	6,0
	HPC 865	21	65	65,2	77,2	374,8	14,6	75,0				
	HPC 875	25	75	77,6	89,6	446,2	17,4	85,0				
	HPC 8100	33	100	102,5	114,5	589,0	22,9	110,0				
HPC 8125	41	125	127,3	139,3	731,8	28,5	135,0					
HPC 8150	49	150	152,1	164,1	874,6	34,1	160,0					
	HPC 8200	65	200	201,8	213,8	1160,2	45,2	210,0				

Dimensions in mm – Design breaking load in kN – RZ (Number of rows) = number of all link plates per joint – Other pitches and widths on request.

- HPC inverted tooth chains are delivered open and with a split pin lock if not specified otherwise.
- Revolving chains require an even number of links. Chains with an uneven number of links could not be closed.
- Uneven numbers of links are permitted only if the ends of the chain are connected to external parts.

HPC inverted tooth sprockets

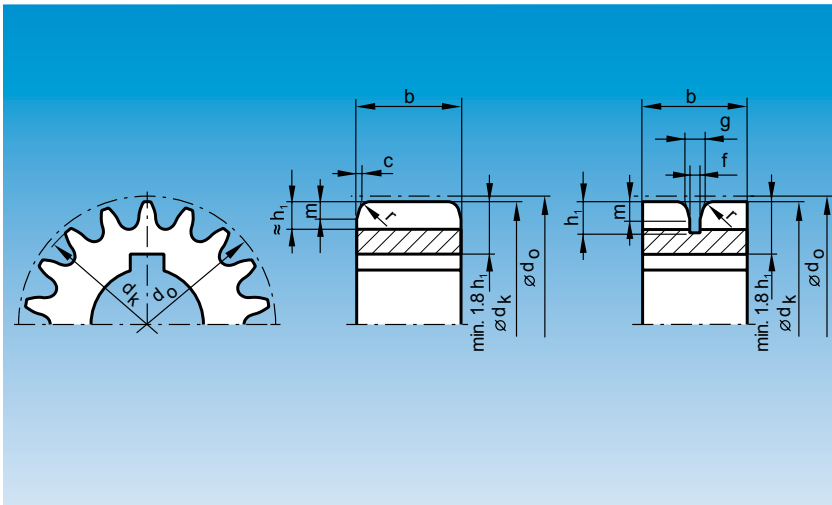

Minimum number of teeth:

3/8" to 3/4" = 17 teeth

1", 1 1/2" = 19 teeth

from 1 m/s ≥ 23 teeth

Tip diameter d_k

Number of teeth z	3/8"	1/2"	3/4"	1"	1 1/2"
17	46,3	61,5	92,7	–	–
18	49,5	65,7	98,9	–	–
19	52,6	69,9	105,1	139,8	210,4
20	55,7	74,0	111,4	148,1	222,8
21	58,8	78,2	117,6	156,4	235,2
22	61,9	82,3	123,8	164,6	247,5
23	65,0	86,4	129,9	172,8	259,9
24	68,1	90,5	136,1	181,1	272,2
25	71,1	94,7	142,3	189,3	284,5
26	74,2	98,8	148,4	197,5	296,8
27	77,3	102,9	154,6	205,7	309,0
28	80,4	107,0	160,7	213,8	321,3
29	83,4	111,1	166,8	222,0	333,6
30	86,5	115,1	173,0	230,2	345,8
31	89,6	119,2	179,1	238,4	358,1
33	95,7	127,4	191,3	254,7	382,5
35	101,8	135,6	203,6	271,0	407,0
37	107,9	143,7	215,8	287,3	431,4
39	114,0	151,9	228,0	303,5	455,8
41	120,1	160,0	240,2	319,8	480,2
43	126,2	168,1	252,4	336,0	504,5
45	132,3	176,2	264,6	352,3	528,9
47	138,4	184,4	276,8	368,5	553,2
49	144,5	192,5	288,9	384,8	577,6
51	150,6	200,6	301,1	401,0	601,9
55	162,7	216,8	325,5	433,4	650,6
60	177,9	237,1	355,9	474,0	711,4
70	208,3	277,6	416,6	555,0	832,9
80	238,7	318,1	477,4	636,0	954,4
90	269,1	358,6	538,1	716,9	1075,8
100	299,4	399,1	598,8	797,9	1197,2
110	329,8	439,6	659,5	878,8	1318,6
120	360,1	480,0	720,2	959,7	1439,9
130	390,4	520,5	780,9	1040,6	1561,3
140	420,8	560,9	841,5	1121,5	1682,6
150	451,1	601,4	902,2	1202,4	1803,9

Dimensions in mm – Interpolate intermediate values

Guideway and profile

Pitch p	3/8"	1/2"	3/4"	1"	1 1/2"
g	4,0	4,0	5,0	8,0	9,0
f	3,0	3,0	4,0	6,0	6,0
h₁	5,5	7,0	11,0	14,0	22,0
m	4,0	5,0	8,0	9,0	16,0
r	2,0	2,0	3,0	3,0	4,0
c	0,5	0,5	0,5	1,0	1,5

The pitch circle diameter helps determine the correct external diameter of the sprocket with an attached chain in new condition.

Pitch circle diameter:

$$d_0 = \frac{p}{\sin(180^\circ/z)}$$

Max. diameter incl. chain

$$D_{\max} = d_0 + 2 \cdot (H-o)$$

Biflex inverted tooth chain drives

The highest flexibility possible—symmetrically toothed link plates on both sides yield equal performance and precision during bilateral use. It's the ideal solution for changes in direction of rotation or for multi-shaft drives.



More freedom with BIFLEX inverted tooth chains

BIFLEX link plates are completely symmetrical and provide full interlocking with the sprockets on both sides.

- As a drive for counter-running shafts
- As a drive for any number of shafts using an S-shaped wrap
- As an alternative to tensioning the inverted tooth chain when space is tight—idler sprockets can mesh on both sides
- As a drive along the lines of the pin wheel principle with tangential engagement



Flexible to both sides

A balanced combination

This chain connects the advantages of the well-established HDL technology with equivalent properties for both sides and directions.

- Uses the same joint profile as the HDL model.
- Pivot pins are arranged symmetrically. These move to the center in tensioned chains, thereby permitting the same amount of bending in each direction.

- Joints experience longitudinal play in straight position, i.e., the chain links can be pushed together slightly. This play is essential for the function, but the compression effect does not appear in practice due to missing pressure forces.

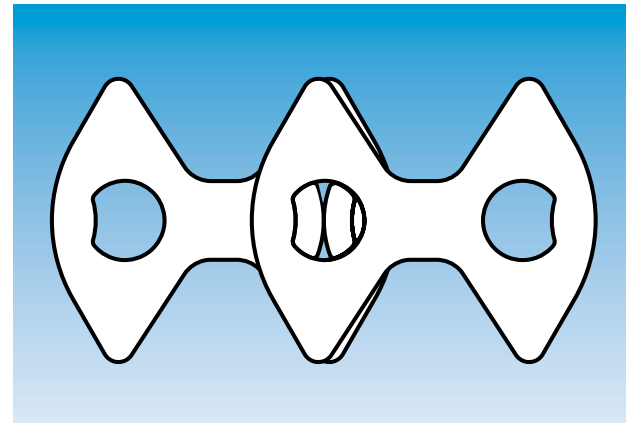

Calculation formulas

$$P = \frac{M \cdot n}{9550}$$

$$v = \frac{Z \cdot p \cdot n}{60000} \leq 40 \text{ m/s}$$

With:

P = power in kW
 M = torque in Nm
 n = speed in r.p.m.
 v = velocity in m/s
 Z = number of teeth
 p = pitch in mm

Note: Torque M and speed n must refer to the same sprocket with the number of teeth Z.

Step 1:

$$F_{\text{Berf}}^* \geq \frac{P \cdot k}{v} \cdot S_{\text{min}}$$

Step 2:

$$F_{\text{Berf}} \geq \left(\frac{P \cdot k}{v} + G \cdot v^2 \cdot 10^{-3} \right) \cdot S_{\text{min}}$$

With:

F_{Berf} = design breaking load in kN
 P = power in kW
 k = impact factor according to table
 v = velocity in m/s
 G = inverted tooth chain weight in kg/m
 S_{min} = type/application-dependent safety coefficient BIFLEX = 8...10

The impact factor must be adjusted to the actual torque in case of maximum speed. In general, a value of $k = 1$ is sufficient, deviating from the start-up behavior.

Design impact factor values

Load	Drive motors		
	Soft startup drive	Three-phase current motor	Piston motor
Even	1.0	1.2	1.5
Medium impacts	1.3	1.5	2.0
Heavy impacts	≥ 1.7	≥ 2.0	≥ 2.5

How to calculate the required design breaking load:

1. Initial calculation according to step 1.
2. Select an inverted tooth chain from the table on page 18.
3. Recalculate according to step 2 and select again if necessary.

Biflex inverted tooth chains

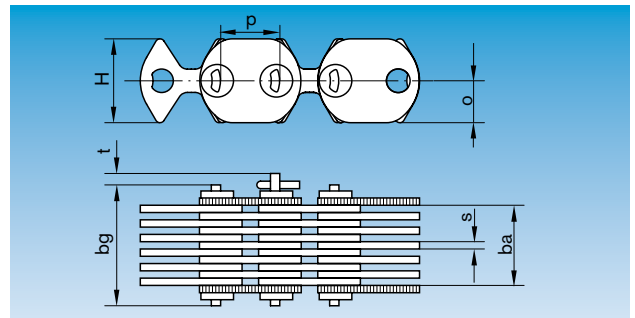
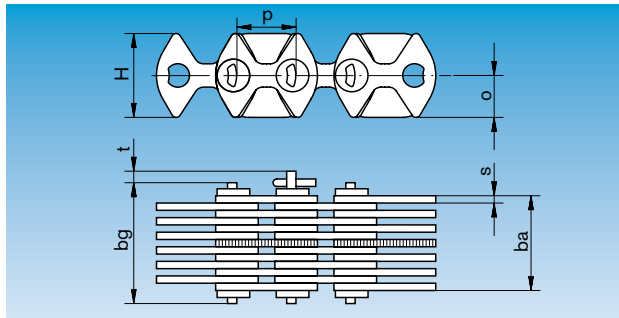

Pitch p	Designation no.	RZ	Nominal width b_n	Working width b_a	Total width b_g	Design breaking load [kg/m]	Weight [kg/m]	Sprocket width b	H	o	s	t
3/8" = 9.525 mm	BIZ 015 A	10	15	12.5	19.9	16.4	0.9	11.5	14.0	7.0	1.5	2.0
	BIZ 020 A	13	20	17.2	24.5	20.1	1.2	16.0				
	BIZ 025	17	25	26.6	30.8	31.0	1.4	30.0				
	BIZ 030	21	30	32.9	37.1	38.3	1.8	35.0				
	BIZ 040	25	40	39.1	43.3	45.6	2.1	45.0				
	BIZ 050	33	50	51.6	55.8	60.3	2.8	55.0				
	BIZ 065	41	65	64.2	68.4	74.9	3.5	70.0				
1/2" = 12.7 mm	BIZ 315 A	10	15	12.5	21.3	27.9	1.2	11.5	18.0	9.0	1.5	2.5
	BIZ 320 A	13	20	17.2	25.9	34.1	1.6	16.0				
	BIZ 325	17	25	26.6	32.2	52.7	1.9	30.0				
	BIZ 330	21	30	32.9	38.5	65.1	2.4	35.0				
	BIZ 340	25	40	39.1	44.7	77.5	2.8	45.0				
	BIZ 350	33	50	51.6	57.2	102.3	3.7	55.0				
	BIZ 365	41	65	64.2	69.8	127.2	4.6	70.0				
	BIZ 375	49	75	76.7	82.3	152.0	5.5	80.0				
	BIZ 380	53	80	82.9	88.5	164.4	5.9	85.0				
	BIZ 3100	65	100	101.7	107.3	201.6	7.3	105.0				
	BIZ 3125	81	125	126.8	132.4	251.3	9.1	130.0				
	BIZ 3150	97	150	151.8	157.4	300.9	10.9	155.0				
3/4" = 19.05 mm	BIZ 530 A	15	30	27.0	38.2	77.3	3.5	26.0	27.0	13.5	2.0	3.5
	BIZ 535	17	35	35.4	42.4	101.1	3.8	40.0				
	BIZ 550	25	50	52.0	59.0	148.7	5.6	55.0				
	BIZ 565	33	65	68.6	75.6	196.3	7.4	75.0				
	BIZ 585	41	85	85.3	92.3	243.9	9.2	90.0				
	BIZ 590	45	90	93.6	100.6	267.7	10.1	100.0				
	BIZ 5100	49	100	101.9	108.9	291.5	11.0	105.0				
	BIZ 5125	61	125	126.9	133.9	362.9	13.7	130.0				
	BIZ 5135	65	135	135.2	142.2	386.7	14.6	140.0				
	BIZ 5150	73	150	151.8	158.8	434.3	16.4	155.0				
	BIZ 5200	97	200	201.8	208.8	577.1	21.8	205.0				
1" = 25.4 mm	BIZ 640	13	40	40.2	48.2	151.9	5.8	45.0	36.0	18.0	3.0	6.0
	BIZ 650	17	50	52.6	60.6	198.6	7.6	55.0				
	BIZ 665	21	65	65.0	73.0	245.4	9.4	70.0				
	BIZ 675	25	75	77.4	85.4	292.1	11.2	80.0				
	BIZ 6100	33	100	102.1	110.1	385.6	14.8	105.0				
	BIZ 6125	41	125	126.9	134.9	479.1	18.4	130.0				
	BIZ 6150	49	150	151.7	159.7	572.6	22.0	155.0				
	BIZ 6200	65	200	201.2	209.2	759.6	29.2	205.0				

Dimensions in mm – Design breaking load in kN – RZ (Number of rows) = number of all link plates per joint – Other pitches and widths on request.

- Biflex inverted tooth chains are delivered open and with a split pin lock if not specified otherwise.
- Revolving chains require an even number of links. Chains with an uneven number of links could not be closed.
- Uneven numbers of links are permitted only if the ends of the chain are connected to external parts.

Biflex inverted tooth sprockets

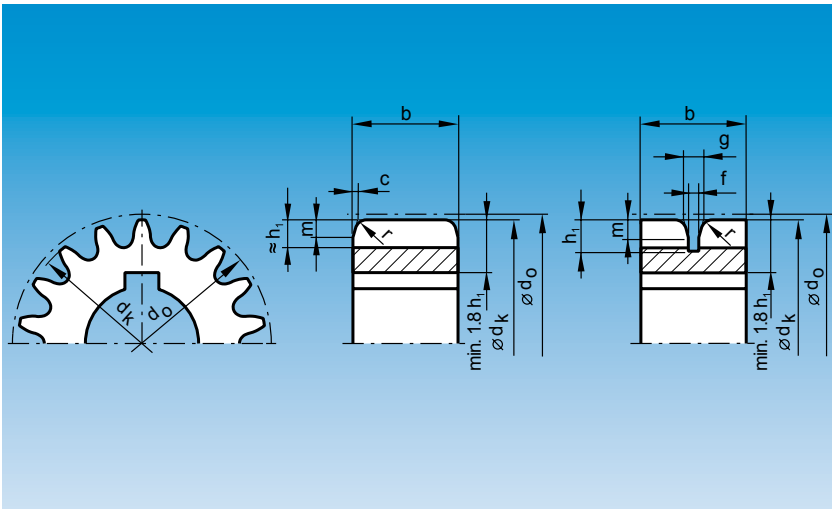

Minimum number of teeth:

3/8", 1/2", 3/4" = 18 teeth

1" = 19 teeth

Z ≥ 23 is preferred.

Use smaller numbers of teeth only on sprockets which transfer torque at velocities up to $v = 1$ m/s.

Tip diameter d_k

Number of teeth z	3/8"	1/2"	3/4"	1"
18	49.0	65.3	98.3	-
19	52.1	69.5	104.5	139.4
20	55.2	73.6	110.7	147.6
21	58.3	77.7	116.9	155.8
22	61.4	81.8	123.0	164.0
23	64.5	85.9	129.2	172.2
24	67.5	90.0	135.3	180.4
25	70.6	94.1	141.5	188.6
26	73.7	98.2	147.6	196.8
27	76.7	102.3	153.7	204.9
28	79.8	106.4	159.8	213.1
29	82.9	110.5	166.0	221.3
30	85.9	114.6	172.1	229.4
31	89.0	118.7	178.2	237.6
33	95.1	126.8	190.4	253.6
35	101.2	134.9	202.6	270.1
37	107.3	143.1	214.8	286.4
39	113.4	151.2	227.0	302.6
41	119.5	159.3	239.2	318.9
43	125.6	167.5	251.3	335.1
45	131.7	175.6	263.5	351.3
47	137.8	183.7	275.7	367.6
49	143.9	191.8	287.8	383.8
51	149.9	199.9	300.0	400.0
55	162.1	216.1	324.3	432.4
60	177.3	236.4	354.7	472.9
70	207.7	276.9	415.4	553.9
80	238.0	317.4	476.2	634.9
90	268.4	357.9	536.9	715.8
100	298.7	398.3	597.5	796.7
110	329.1	438.8	658.2	877.6
120	359.4	479.2	718.9	958.5
130	389.8	519.7	779.6	1039.4
140	420.1	560.1	840.2	1120.3
150	450.4	600.6	900.9	1201.2

Dimensions in mm – Interpolate intermediate values

Guideway and profile

Pitch p	3/8"	1/2"	3/4"	1"
g	4.0	4.0	5.0	8.0
f	3.0	3.0	4.0	6.0
h_1	5.5	7.0	11.0	14.0
m	4.0	5.0	8.0	9.0
r	2.0	2.0	3.0	3.0
c	0.5	0.5	0.5	1.0

The pitch circle diameter helps determine the correct external diameter of the sprocket with an attached chain in new condition.

Pitch circle diameter:

$$d_0 = \frac{p}{\sin(180^\circ/z)}$$

Max. diameter incl. chain

$$D_{\max} = d_0 + 2 \cdot (H - o)$$

Specific solutions with specific variants

Special components



- Special links are easily integrated as drivers or incremental transducers.
- Parts from other manufacturers can be easily incorporated using special link plates or adapter pieces.

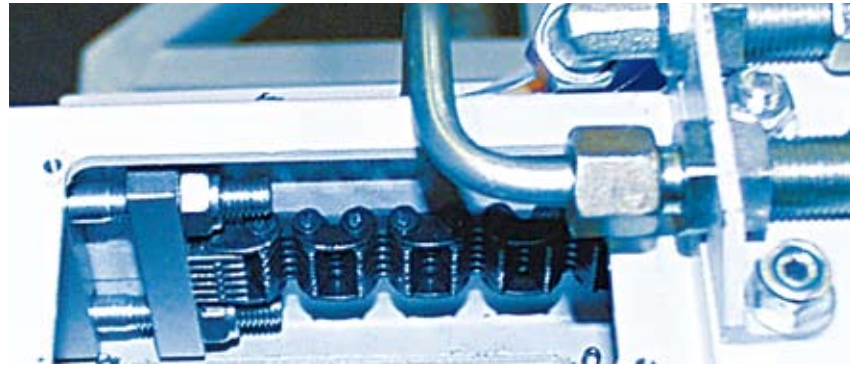

Special types

- Made from stainless steel
- With specially treated surfaces
- For clean room applications
- Special joints for inverted tooth chains without rigid backing



Specific solutions for specific tasks

Special applications

Roller table drive applications

- Cost-efficient group drive
- Uniform synchronous running
- No backlash when reversing
- Quiet even at high speeds
- Good meshing conditions minimize wear

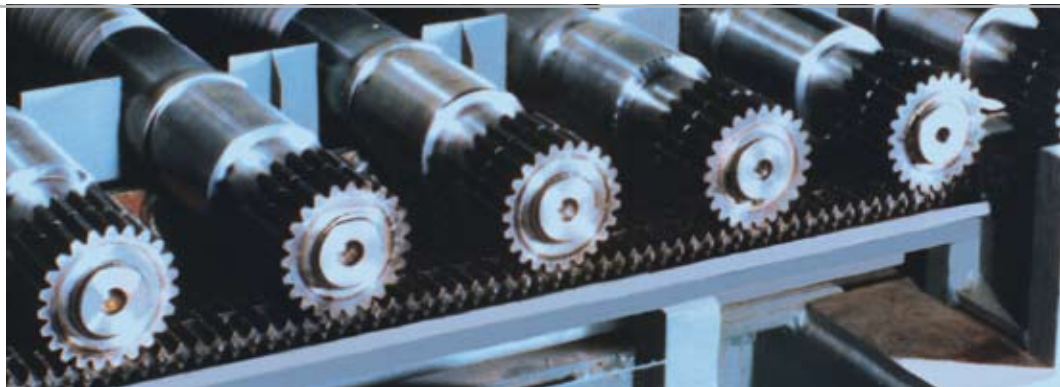

Gear rim applications

- More cost-efficient than a milled gear rim
- Suitable for large transmission ratios
- Full circle rotary motion or swivel motion along an angle segment possible in reverse or continuously

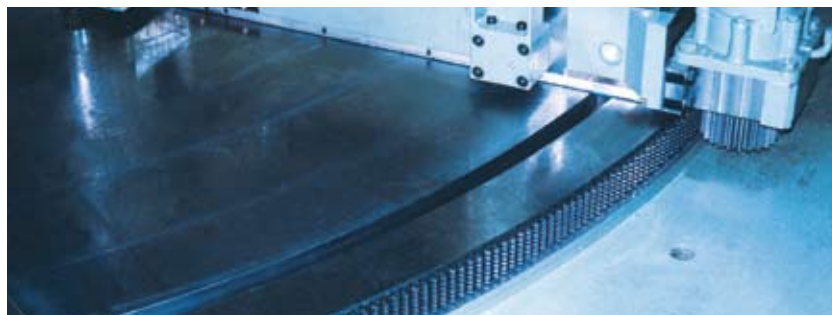

Gripper and robot drive applications

- Precise synchronized motion
- High load capacity even at narrow widths
- Optimum meshing depth on the toothing provides a high degree of security against skipping



Flexible shaft coupling applications

- High elasticity
- Uncouples quickly by opening the lock or by axial movement while chain stays closed
- Angles can be shifted to 1° and shafts can be shifted radially to 2% of the pitch



Specific solutions for specific applications

Special designs—when the ordinary is no longer sufficient



CC compact inverted tooth chains

- Chain links made from solid link plate blocks of maximum durability
- Sprockets with involute-toothing in special versions
- Intended for slow runners with the highest possible power density
- Available in many sizes and models from 3/8" to 2 1/2" pitch, in special pitches up to 5"
- Also available with HPC pivot pins or round bolts—chains either have rigid backing or can be bent over both sides



Tow chains

- Able to transfer heavy tensile loads while small in size
- Product carriers can be coupled by integrated sleeves or work-piece support using integrated bolts
- Particularly low height when installed in horizontal position
- Unmeshed cover link plates can provide screening

Pusher tooth chains

- Thrusts transmitted via link plate contact surface
- Involute-toothing creates ideal meshing conditions on the sprocket
- For especially quiet stroke drives



Optimally configured for special applications

Special inverted tooth chains in special pitches

Combine inverted tooth chain components or specific product advantages to customized solutions, e.g.:

- Low-wear rolling pivot joint to increase velocity
- Compact link plate construction to maximize power transmission
- Involute-toothing on sprockets for extremely quiet running

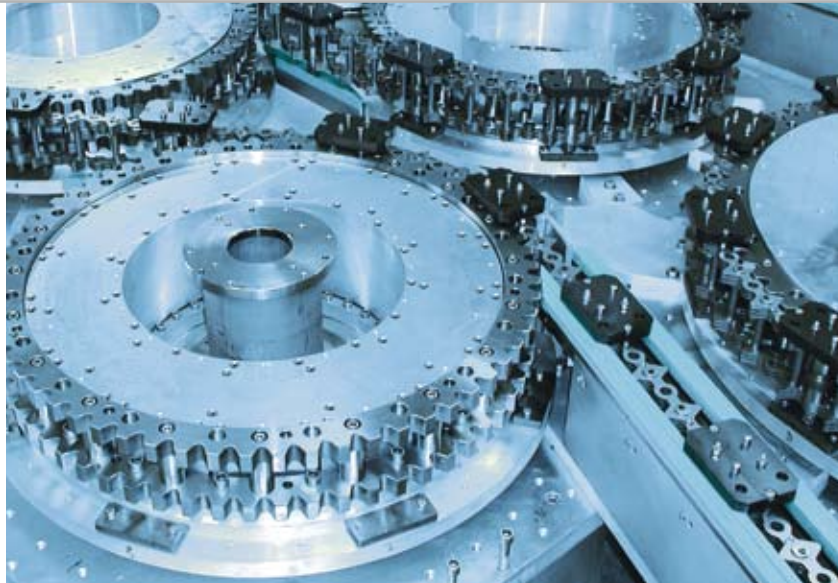

Special link plate forms optimized for the application
Complex geometries through cutting-edge manufacturing processes

Advantages of using Rexroth inverted tooth chain solutions over the alternatives ...

... customer's own design

- Cost savings
- Development capacity freed up
- Comprehensive cross-sector expertise from nearly 100 years of development activities

... standard solutions based on roller chains

- Higher quality tooth meshing and quieter running
- Less elongation
- Increased permissible speed
- Less requirements regarding lubrication and maintenance

HDL inverted tooth chain drives



The first optimization: Inverted tooth chains per DIN 8190

Improvements to the link plate form and joint kinematics compared to the KH type help transfer larger forces within smaller spaces and enable velocities of up to 40 m/s. An important milestone on the road towards the HPC type.

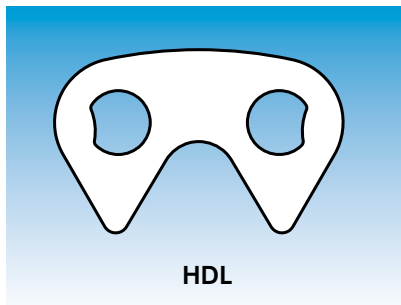

A tradition of quality

Our inverted tooth chains are always state-of-the-art. HDL inverted tooth chain drives have set numerous records and even today are considered an efficient solution for specific applications.



“Aerodynamic Research Volkswagen” – A trial vehicle equipped with a high-performance inverted tooth chain drive has set a number of world records.

KH inverted tooth chain drives

The forefather of drive chains with a rolling pivot joint

KH model inverted tooth chains set the stage for the triumph of inverted tooth chain drives in demanding applications. Available in pitches from 5/16" to 2" as a standard design in many older systems. Also available as a special 2 1/2" design for heavy-duty drives and slow running machines (e.g. KH 11350, 2 1/2" x 350 mm). Please get in touch with us if you would like more information.

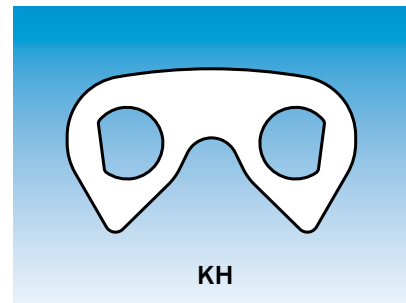
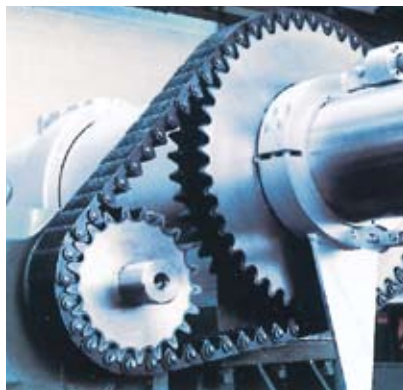

A tradition of quality

Our inverted tooth chains have always been at the front of the pack when it comes to moving large objects. Even today, KH inverted tooth chains are still used in special applications.

During the construction of the Elbe tunnel in Hamburg, KH inverted tooth chains were put to work as the gear rim for the tunneling machine.

HDL inverted tooth chains

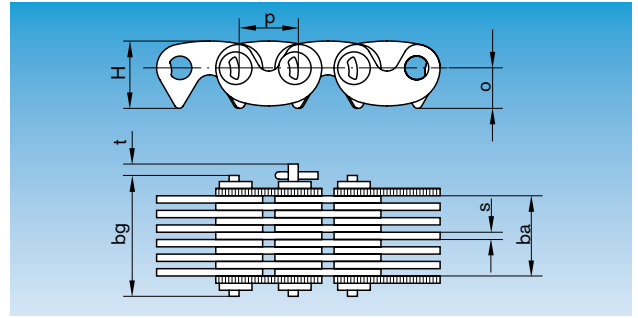
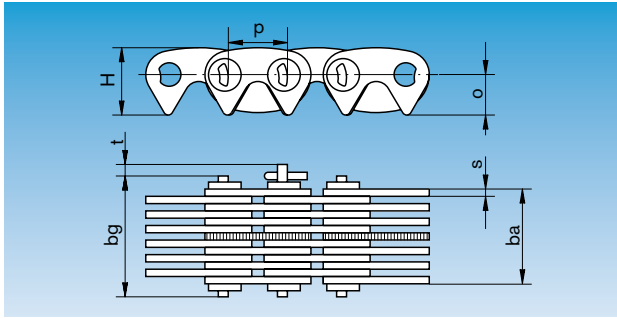

Pitch p	Designation no.	RZ	Nominal width b_n	Working width b_a	Total width b_g	Design breaking load	Weight [kg/m]	Sprocket width b	H	o	s	t
3/8" = 9.525 mm	HDL 015 A	10	15	12.5	19.9	14.5	0.9	11.5	10.9	6.7	1.5	2.0
	HDL 020 A	13	20	17.2	24.5	17.7	1.1	16.0				
	HDL 025	17	25	26.6	30.8	27.4	1.4	30.0				
	HDL 030	21	30	32.9	37.1	33.9	1.7	35.0				
	HDL 040	25	40	39.1	43.3	40.3	2.0	45.0				
	HDL 050	33	50	51.6	55.8	53.2	2.6	55.0				
1/2" = 12.7 mm	HDL 065	41	65	64.2	68.4	66.2	3.3	70.0	14.5	8.7	1.5	2.5
	HDL 315 A	10	15	12.5	21.3	20.2	1.1	11.5				
	HDL 320 A	13	20	17.2	25.9	24.7	1.4	16.0				
	HDL 325	17	25	26.6	32.2	38.2	1.8	30.0				
	HDL 330	21	30	32.9	38.5	47.3	2.2	35.0				
	HDL 340	25	40	39.1	44.7	56.3	2.6	45.0				
	HDL 350	33	50	51.6	57.2	74.3	3.4	55.0				
	HDL 365	41	65	64.2	69.8	92.3	4.3	70.0				
	HDL 375	49	75	76.7	82.3	110.3	5.1	80.0				
HDL 3100	65	100	101.7	107.3	146.4	6.7	105.0					
3/4" = 19.05 mm	HDL 530 A	15	30	27.0	38.2	59.6	3.3	26.0	21.0	10.7	2.0	3.5
	HDL 535	17	35	35.4	42.4	78.0	3.7	40.0				
	HDL 540	21	40	43.7	50.7	96.3	4.5	50.0				
	HDL 550	25	50	52.0	59.0	114.7	5.4	55.0				
	HDL 565	33	65	68.6	75.6	151.4	7.1	75.0				
	HDL 585	41	85	85.3	92.3	188.1	8.9	90.0				
	HDL 5100	49	100	101.9	108.9	224.9	10.6	105.0				
	HDL 5125	61	125	126.9	133.9	279.9	13.2	130.0				
	HDL 5150	73	150	151.8	158.8	335.0	15.8	155.0				
	HDL 5200	97	200	201.8	208.8	445.2	20.9	205.0				
1" = 25.4 mm	HDL 640	13	40	40.2	48.2	112.1	5.6	45.0	27.7	14.0	3.0	6.0
	HDL 650	17	50	52.6	60.6	146.6	7.3	55.0				
	HDL 665	21	65	65.0	73.0	181.1	9.0	70.0				
	HDL 675	25	75	77.4	85.4	215.6	10.7	80.0				
	HDL 6100	33	100	102.1	110.1	284.7	14.1	105.0				
	HDL 6125	41	125	126.9	134.9	353.7	17.5	130.0				
	HDL 6150	49	150	151.7	159.7	422.7	21.0	155.0				
	HDL 6200	65	200	201.2	209.2	560.7	27.8	205.0				

Dimensions in mm – Design breaking load in kN – RZ (Number of rows) = number of all link plates per joint – Other pitches and widths on request.

- HDL inverted tooth chains are delivered open and with a split pin lock if not specified otherwise.
- Revolving chains require an even number of links. Chains with an uneven number of links could not be closed.
- Uneven numbers of links are permitted only if the ends of the chain are connected to external parts.

HDL inverted tooth sprockets

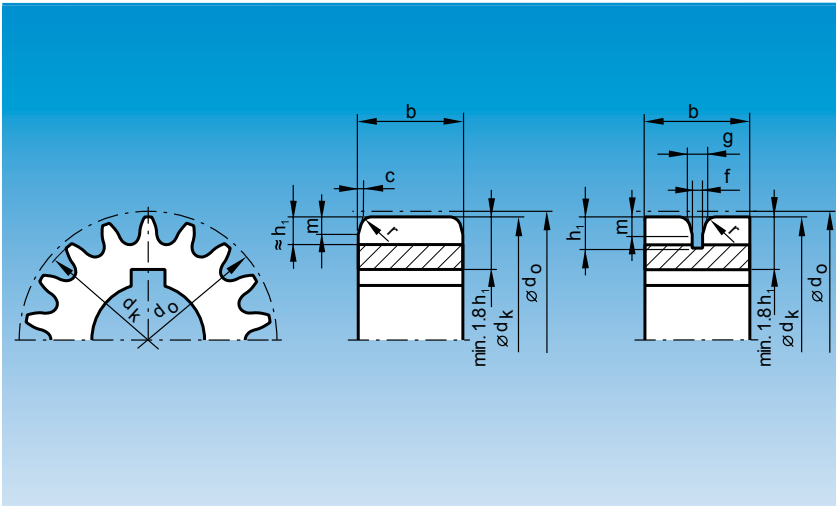

Tip diameter d_k

Number of teeth z	3/8"	1/2"	3/4"	1"
17	48.1	63.9	100.7	134.3
18	51.2	68.0	106.9	142.6
19	54.3	72.2	113.1	150.8
20	57.4	76.3	119.3	159.1
21	60.5	80.4	125.5	167.3
22	63.5	84.6	131.6	175.5
23	66.6	88.7	137.8	183.7
24	69.7	92.8	143.9	191.9
25	72.8	96.9	150.0	200.1
26	75.8	101.0	156.2	208.3
27	78.9	105.0	162.3	216.4
28	82.0	109.1	168.4	224.6
29	85.0	113.2	174.5	232.7
30	88.1	117.3	180.7	240.9
31	91.2	121.4	186.8	249.0
33	97.3	129.5	199.0	265.3
35	103.4	137.7	211.2	281.6
37	109.5	145.8	223.4	297.9
39	115.6	153.9	235.6	314.1
41	121.7	162.1	247.8	330.3
43	127.8	170.2	260.0	346.6
45	133.9	178.3	272.1	362.8
47	139.9	186.4	284.3	379.0
49	146.0	194.5	296.4	395.3
51	152.1	202.6	308.6	411.5
55	164.3	218.9	332.9	443.9
60	179.5	239.1	363.3	484.4
70	209.9	279.6	424.0	565.4
80	240.2	320.1	484.8	646.4
90	270.6	360.6	545.5	727.3
100	300.9	401.1	606.1	808.2
110	331.3	441.5	666.8	889.1
120	361.6	482.0	727.5	970.0
130	391.9	522.4	788.2	1050.9
140	422.3	562.8	848.8	1131.8
150	452.6	603.3	909.5	1212.6

Dimensions in mm—Interpolate intermediate values

Minimum number of teeth:

The theoretical minimum is 17, but in practice, it should not be below 23 teeth.

Guideway and profile

Pitch p	3/8"	1/2"	3/4"	1"
g	4.0	4.0	5.0	8.0
f	3.0	3.0	4.0	6.0
h_1	6.0	7.0	12.0	15.0
m	4.0	5.0	8.0	10.0
r	2.0	2.0	3.0	3.0
c	0.5	0.5	0.5	1.0

The pitch circle diameter helps determine the correct external diameter of the sprocket with an attached chain in new condition.

Pitch circle diameter:

$$d_0 = \frac{p}{\sin(180^\circ/z)}$$

Max. diameter incl. chain

$$D_{\max} = d_0 + 2 \cdot (H - o)$$

KH inverted tooth chains

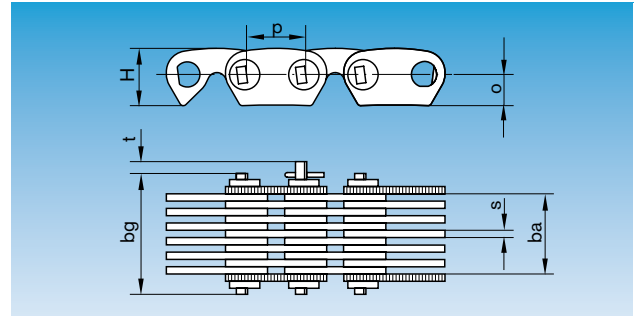
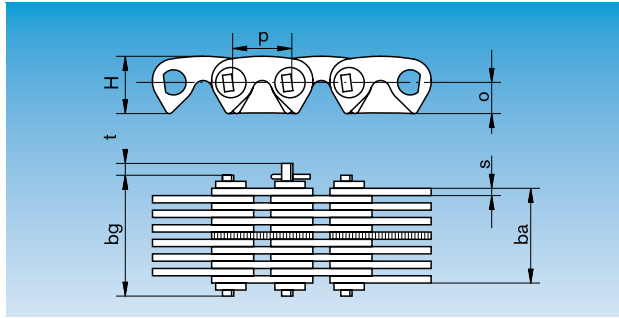

Pitch p	Designation no.	RZ	Nominal width b_n	Working width b_a	Total width b_g	Design breaking load	Weight [kg/m]	Sprocket width b	H	o	s	t
5/16" = 7.9375 mm	KH 2212 A	12	12	10.7	16.8	5.6	0.5	9.5	7.7	4.2	1.0	2.0
	KH 2215 A	14	15	12.8	18.9	6.6	0.6	11.5				
	KH 2220 A	18	20	17.0	23.2	8.6	0.7	15.5				
	KH 2225	25	25	26.6	30.6	12.7	0.9	30.0				
3/8" = 9.525 mm	KH 015 A	10	15	12.5	19.9	12.1	0.8	11.5	9.2	5.2	1.5	2.0
	KH 020 A	13	20	17.2	24.5	14.8	1.0	16.0				
	KH 025	17	25	26.6	30.8	22.9	1.1	30.0				
	KH 030	21	30	32.9	37.1	28.3	1.4	35.0				
	KH 040	25	40	39.1	43.3	33.7	1.7	45.0				
1/2" = 12.7 mm	KH 315 A	10	15	12.5	21.3	16.0	1.0	11.5	12.3	6.7	1.5	2.5
	KH 320 A	13	20	17.2	25.9	19.6	1.2	16.0				
	KH 325	17	25	26.6	32.2	30.3	1.4	30.0				
	KH 330	21	30	32.9	38.5	37.4	1.8	35.0				
	KH 340	25	40	39.1	44.7	44.6	2.1	45.0				
	KH 350	33	50	51.6	57.2	58.9	2.8	55.0				
5/8" = 15.875 mm	KH 425	13	25	27.0	32.8	39.7	1.9	30.0	15.4	8.4	2.0	3.0
	KH 435	17	35	35.4	41.2	52.0	2.5	40.0				
	KH 450	25	50	52.0	57.8	76.5	3.6	55.0				
	KH 465	33	65	68.6	74.4	100.9	4.8	70.0				
3/4" = 19.05 mm	KH 535	17	35	35.4	42.4	65.0	2.9	40.0	18.5	10.1	2.0	3.5
	KH 550	25	50	52.0	59.0	95.6	4.3	55.0				
	KH 565	33	65	68.6	75.6	126.2	5.7	75.0				
	KH 575	37	75	77.0	84.0	141.5	6.4	80.0				
1" = 25.4 mm	KH 650	17	50	52.6	60.6	126.4	5.9	55.0	24.6	13.1	3.0	4.0
	KH 665	21	65	65.0	73.0	156.1	7.3	70.0				
	KH 675	25	75	77.4	85.4	185.9	8.7	80.0				
	KH 6100	33	100	102.1	110.1	245.4	11.4	105.0				
1 1/2" = 38.1 mm	KH 865	21	65	65.2	77.2	232.0	10.8	75.0	36.9	20.1	3.0	6.0
	KH 875	25	75	77.6	89.6	276.2	12.9	85.0				
	KH 8100	33	100	102.5	114.5	364.6	17.0	110.0				
	KH 8150	49	150	152.1	164.1	541.4	25.2	160.0				
2" = 50.8 mm	KH 9100	25	100	104.5	117.5	478.1	22.6	110.0	49.2	26.8	4.0	7.0
	KH 9115	29	115	121.2	134.2	554.6	26.2	125.0				
	KH 9150	37	150	154.7	167.7	707.6	33.5	160.0				
	KH 9180	45	180	188.1	201.1	860.6	40.7	190.0				

Dimensions in mm – Design breaking load in kN – RZ (Number of rows) = number of all link plates per joint – Other pitches and widths on request.

- KH inverted tooth chains are delivered open and with a split pin lock if not specified otherwise.
- Uneven numbers of links are permitted for revolving chains. However, in this case the design breaking load will be reduced to approx. 80% of the value in the table.
- Uneven numbers of links are also permitted if the ends of the chain are connected to external parts.

KH inverted tooth sprockets

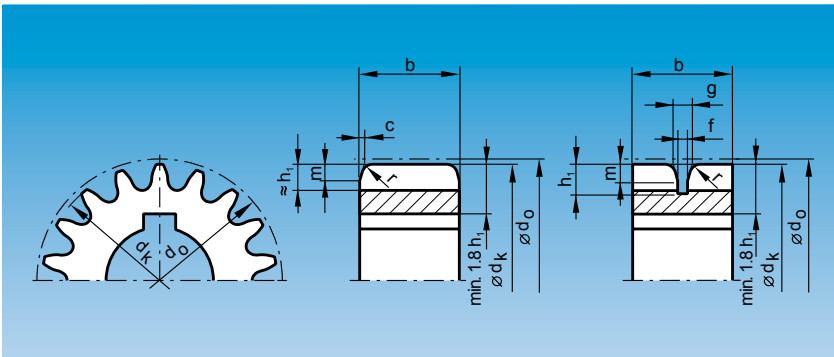

Minimum number of teeth:

5/16" to 3/4" = 13 teeth

from 1" = 15 teeth

Tip diameter d_k

Number of teeth z	5/16"	3/8"	1/2"	5/8"	3/4"	1"	1 1/2"	2"
13	31.9	38.6	51.5	64.4	77.2	-	-	-
14	34.5	41.7	55.6	69.5	83.4	-	-	-
15	37.1	44.8	59.7	74.6	89.6	119.4	179.2	238.9
16	39.7	47.9	63.8	79.8	95.7	127.6	191.5	255.4
17	42.3	51.0	67.9	84.9	101.9	135.8	203.8	271.7
18	44.9	54.0	72.0	90.0	108.0	144.0	216.0	288.1
19	47.4	57.1	76.1	95.1	114.1	152.2	228.3	304.4
20	50.0	60.1	80.1	100.2	120.2	160.3	240.5	320.7
21	52.5	63.2	84.2	105.3	126.3	168.5	252.7	337.0
22	55.1	66.3	88.3	110.4	132.4	176.6	264.9	353.3
23	57.7	69.3	92.3	115.4	138.5	184.7	277.1	369.5
24	60.2	72.3	96.4	120.5	144.6	192.9	289.3	385.8
25	62.8	75.4	100.5	125.6	150.7	201.0	301.5	402.1
26	65.3	78.4	104.5	130.7	156.8	209.1	313.7	418.3
27	67.8	81.5	108.6	135.8	162.9	217.3	325.9	434.6
28	70.4	84.5	112.7	140.8	169.0	225.4	338.1	450.8
29	72.9	87.6	116.7	145.9	175.1	233.5	350.3	467.0
30	75.5	90.6	120.8	151.0	181.2	241.6	362.4	483.3
31	78.0	93.7	124.8	156.1	187.3	249.7	374.6	499.5
33	83.1	99.8	133.0	166.2	199.5	266.0	399.0	532.0
35	88.2	105.8	141.1	176.3	211.6	282.2	423.3	564.4
37	93.2	111.9	149.2	186.5	223.8	298.4	447.6	596.8
39	98.3	118.0	157.3	196.6	235.9	314.6	471.9	629.2
41	103.4	124.1	165.4	206.7	248.1	330.8	496.2	661.6
43	108.4	130.1	173.5	216.9	260.2	347.0	520.5	694.0
45	113.5	136.2	181.6	227.0	272.4	363.2	544.8	726.4
47	118.6	142.3	189.7	237.1	284.5	379.4	569.1	758.8
49	123.7	148.4	197.8	247.2	296.7	395.6	593.4	791.2
51	128.7	154.5	205.9	257.3	308.8	411.8	617.7	823.6
55	138.8	166.6	222.1	277.6	333.1	444.1	666.2	888.3
60	151.5	181.7	242.3	302.9	363.4	484.6	726.9	969.3
70	176.8	212.1	282.7	353.4	424.1	565.5	848.3	1131.1
80	202.1	242.4	323.2	404.0	484.8	646.4	969.7	1292.9
90	227.4	272.8	363.6	454.6	545.5	727.3	1091.0	1454.7
100	252.7	303.1	404.1	505.1	606.1	808.2	1212.3	1616.4
110	277.9	333.5	444.5	555.6	666.8	889.0	1333.6	1778.1
120	303.2	363.7	484.9	606.2	727.4	969.9	1454.9	1939.9
130	328.5	394.3	525.4	656.8	788.1	1050.8	1576.2	2101.7
140	353.7	424.6	565.8	707.3	848.8	1131.7	1697.6	2263.4
150	379.0	454.7	606.2	757.8	909.4	1212.5	1818.8	2425.1

Dimensions in mm—Interpolate intermediate values

Guideway and profile

Pitch p	5/16"	3/8"	1/2"	5/8"
g	3.5	4.0	4.0	5.0
f	2.5	3.0	3.0	4.0
h ₁	5.0	6.5	8.0	10.0
m	3.0	4.0	5.0	6.0
r	2.0	2.0	2.0	3.0
c	0.5	0.5	0.5	0.5

Pitch p	3/4"	1"	1 1/2"	2"
g	5.0	8.0	9.0	11.0
f	4.0	6.0	6.0	8.0
h ₁	12.0	16.0	23.0	31.0
m	8.0	10.0	16.0	20.0
r	3.0	3.0	4.0	4.0
c	0.5	1.0	1.5	1.5

The pitch circle diameter helps determine the correct external diameter of the sprocket with an attached chain in new condition.

Pitch circle diameter:

$$d_0 = \frac{p}{\sin(180^\circ/z)}$$

Max. diameter incl. chain

$$D_{max} = d_0 + 2 \cdot (H-o)$$

Calculate, order, assemble— Simple and well thought out

Calculating length

$$X = 2 \cdot \frac{a}{p} + Z \quad ; \text{ for } i = 1$$

$$X = 2 \cdot \frac{a}{p} + \frac{Z_1 + Z_2}{2} + \left(\frac{Z_2 - Z_1}{2 \cdot \pi} \right)^2 \cdot \frac{p}{a}$$

Shaft center distance

$$a = \frac{p}{2} \cdot (X - Z) \quad ; \text{ for } i = 1$$

$$a = \frac{p}{4} \cdot \left[X - \frac{Z_1 + Z_2}{2} + \sqrt{\left(X - \frac{Z_1 + Z_2}{2} \right)^2 - 8 \cdot \left(\frac{Z_2 - Z_1}{2 \cdot \pi} \right)^2} \right]$$

X = number of links

a = shaft center distance in mm

p = pitch in mm

Z = number of teeth $Z = Z_1 = Z_2$
for $i = 1$

i = transmission ratio

Z_1 = number of teeth on the
small sprocket

Z_2 = number of teeth on the
large sprocket

Calculating the length

The required length of an inverted tooth chain in links to fit a given center distance can be calculated with the formula provided.

Shaft center distance

With the exception of the KH type, continuous chains can only be closed if they have an even number of links. After selecting the number of links based on the calculated length, the final center distance can be determined.

The formulas shown apply only to drives with two sprockets which comply with the recommended wrap angle and transmission ratios below 6. We are more than happy to perform the calculations for you, especially for drives involving more than two sprockets.

It goes without saying that other commercially available computing programs can also be used.

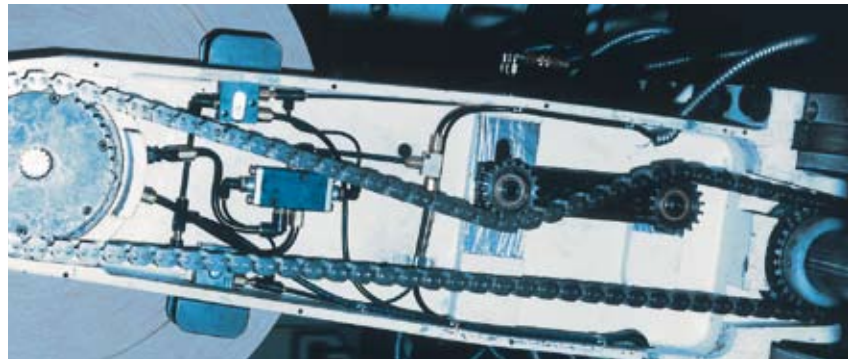

Sales designations for inverted tooth chain drives



1. Type marking

HPC
BIZ
HDL
KH



2. Pitch

22 = 5/16"
0 = 3/8"
3 = 1/2"
4 = 5/8"
5 = 3/4"
6 = 1"
8 = 1 1/2"
9 = 2"
11 = 2 1/2"



3. Nominal width in mm



4. Version marking (optional)

A = External guide
Z = Version with reinforcement plates
D = Double link plates

The inverted tooth chains shown in the tables are a mere selection from our product range. Please get in touch with us if you need a width or pitch not listed here.

What to observe

Sprocket wrap angle

For a proper function of inverted tooth chain drives, a minimum sprocket wrap angle of $\beta = 120^\circ$ must be observed for up to 27 teeth. If more teeth are used, the wrap angle must be at least $\beta = 90^\circ$. The minimum wrap angle of the idler sprocket should be at least:

$$\beta = 360^\circ/Z \quad (Z = \text{number of teeth})$$

Please get in touch with us if you have other operating conditions or require tangential meshing.

Inverted tooth chain tensioning and sag

Pre-tensioning of inverted tooth chains generally is not necessary. The chain has been properly installed when the return strand sags 1% of the distance between the shafts while the loaded chain is running.

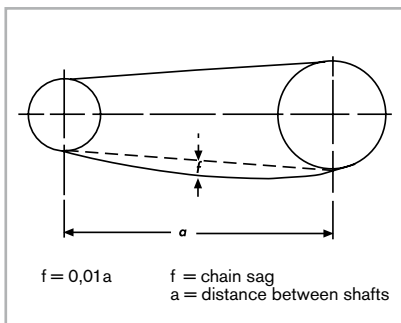

Excess chain slack must be corrected by spacing the shafts farther apart or by using an idler sprocket. In the return strand, idlers are arranged working outwards; in Biflex inverted tooth chains, the wheels also work from outwards to inwards.

Sprocket assembly

The sprockets must be parallel to each other.

Permissible error $Ea \leq 1^\circ$

The sprockets must be aligned correctly.

Permissible error

- **With center guides:** $E_{pc} \leq \text{guideway width } f_{\max} - \text{link plate thickness } s_{\min}$
- **With side guides:** $E_{ps} \leq \text{working width } b_{A\min} - \text{sprocket width } b_{\max}$

The axial play on the sprockets must be minimized.

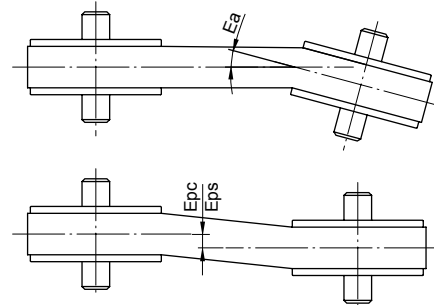

Adjusting and re-tensioning

If pre-tensioning is needed to prevent backlash on reversible drives, the longest strand does not sag when properly adjusted. However, it can be forced manually to up to $\pm 2\%$ of the distance between the shafts. After initial start-up, the chain experiences a first elongation phase. Since this process is based on loads, the chain length, speed, and other factors, it is impossible to predict how long this initial elongation will last. It is quite possible that re-tensioning will be necessary after a short running-in period. Later re-tensioning can be performed as needed (elongation due to operating is substantially less).

Shorter distances between shafts and consistent direction of loaded travel eliminate the need for re-tensioning. Applications which do not feature the option of re-tensioning or lack sufficient tensioning space can also use inverted tooth chains elongated at the factory. This is a special process which pre-empts initial elongation before the chain is delivered.

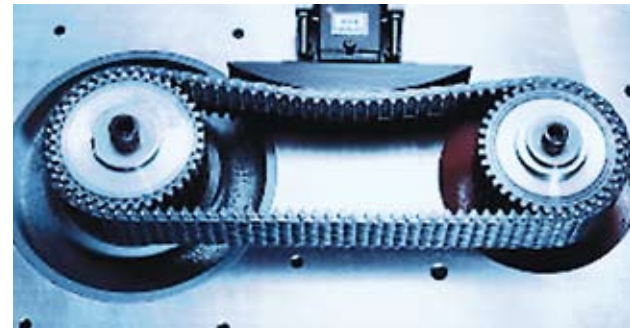

It is also possible to use sliding rails to tension the inverted tooth chains on the backside. The bending radius for HPC inverted tooth chains should be at least 30 times the pitch used. A factor of 20 is sufficient for all other types of inverted tooth chains.

Applying, Closing, Shortening and Lengthening

Assembling inverted tooth chains

Inverted tooth chains are normally delivered open and can be closed with the accompanying split pin or rivet pin lock after installation. If needed, inverted tooth chains can be supplied endless riveted; in such cases, ensure that the chain can be laid on the sprockets without any problems before assembly begins.

Continuous drives require an even number of links—otherwise the ends of the inverted tooth chain will not meet. An uneven number of links is permitted only on inverted tooth chains in which the ends of the chain are connected to external parts such as adapter pieces or tension locks.

Please do not deviate from the instructions given below—they are the prerequisites for the chain drive's trouble-free operation, quiet running, and long service life.

Applying and closing inverted tooth chains with two-pin system

The inverted tooth chain is laid around the sprockets so that both ends can meet in the tothing and mesh with each other if possible. Axle and rolling pivots are consecutively fed into the link plate bore. Important: a wrong pin arrangement can disturb quiet running and can even cause the chain to break under certain circumstances. The rivet washer is then applied, the cotter pin is inserted and closed; rivet closures are riveted manually. The tightness of the rivet washer is an intentional security measure and must not be tampered with by modifying the pin end. Always remember to arrange the axle pins and pivot pins properly.



Shortening and lengthening chains/Note the correct pin assembly

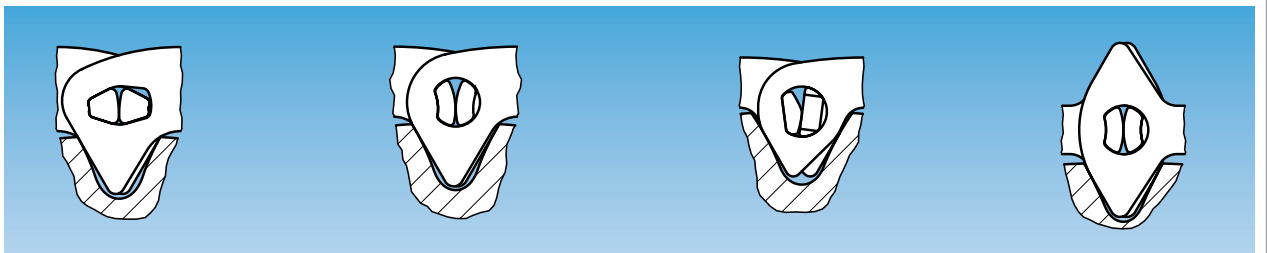

- Open the split pin to open the inverted tooth chain.
- Remove the rivet washer and pull the pin from the joint.
- Grind the rivet head off in case of riveted lock.
- To shorten, proceed in the same manner on the other end of the section to be removed.
- Join the ends and close the inverted tooth chain.

- It is important to pay attention to the correct number and orientation of the link plates.
- To lengthen, join the ends of the section to be inserted with the ends of the inverted tooth chain. Close them as described above with the accompanying split pins or rivet pin locks.

The right lubrication

A well-lubricated inverted tooth chain

is strongly recommended. Depending on ambient conditions, a dry-running chain can experience a much shorter service life. The oil film placed on the chain at the factory is for corrosion protection only and does not act as a lubricant. The type of lubrication is based primarily on the circumferential speed of the inverted tooth chain and can be determined using the diagram below. However, this system does not adequately cover drive cases with an extremely wide range of speed profiles or which operate under harsh ambient conditions. When in doubt, please get in touch with us.

Grease, drip, and spray lubrication

Lubrications with greases capable of flowing, oils with good adhesive and creep characteristics, or lubricants thinned with volatile components. Lubricate regularly according to speed.

Bath lubrication

Lubrication by oil bath immersion. The inverted tooth chain should be set so that its joints are immersed at the deepest point when the chain is stopped.

Automatic lubrication device

Optimum lubrication of the inverted tooth chain without oil-tight housing up to 12 m/s. Lubricant supply 125 or 475 cm³. Minimal amount of lubricant can be applied thanks to adjustable dosage. Lubricant is applied to the chain teeth using tubes and brushes. Up to one year of maintenance-free operation. You can obtain more information from our separate brochure on this topic.

Forced feed lubrication

This requires closed, oil-tight housings. The inverted tooth chain lies above the oil basin and the spray nozzles are directed at the toothed side.



Lubricants

Lubricants in use should generally have a viscosity of at least 220 mm²/s (cSt) according to DIN 51562-01. We also especially recommend for open inverted tooth chain drives the use of sprays such as VISCOGEN KL-23 or comparable. Of course, conventional grease lubrication is also an option although its low creep characteristics may not be sufficient for the required joint lubrication. When in doubt, just let us know—we will check the lubricant you have selected any time.

We are also happy to recommend lubricants for special applications—in the food industry or for high-temperature applications, for instance.

Lubrication dependent on inverted tooth chain velocity

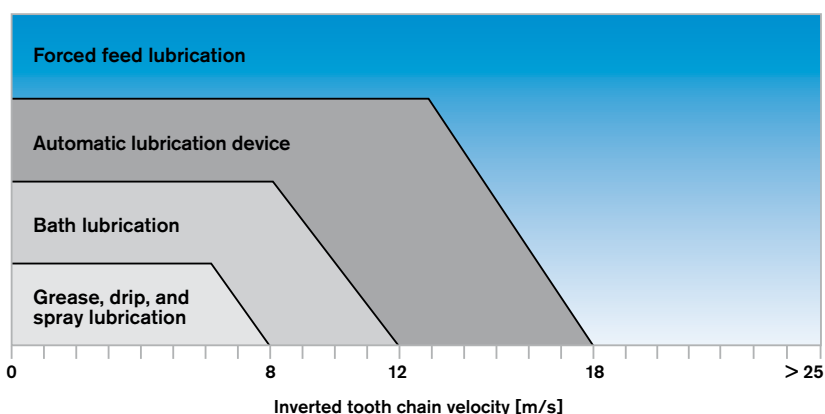

Customer service, engineering, design— Advantages you can dig your teeth into

Using the latest technical methods and field-specific knowledge needed for the customer's tasks, we calculate and develop the most suitable configuration. Inverted tooth chains and sprockets are perfectly adapted to each other.

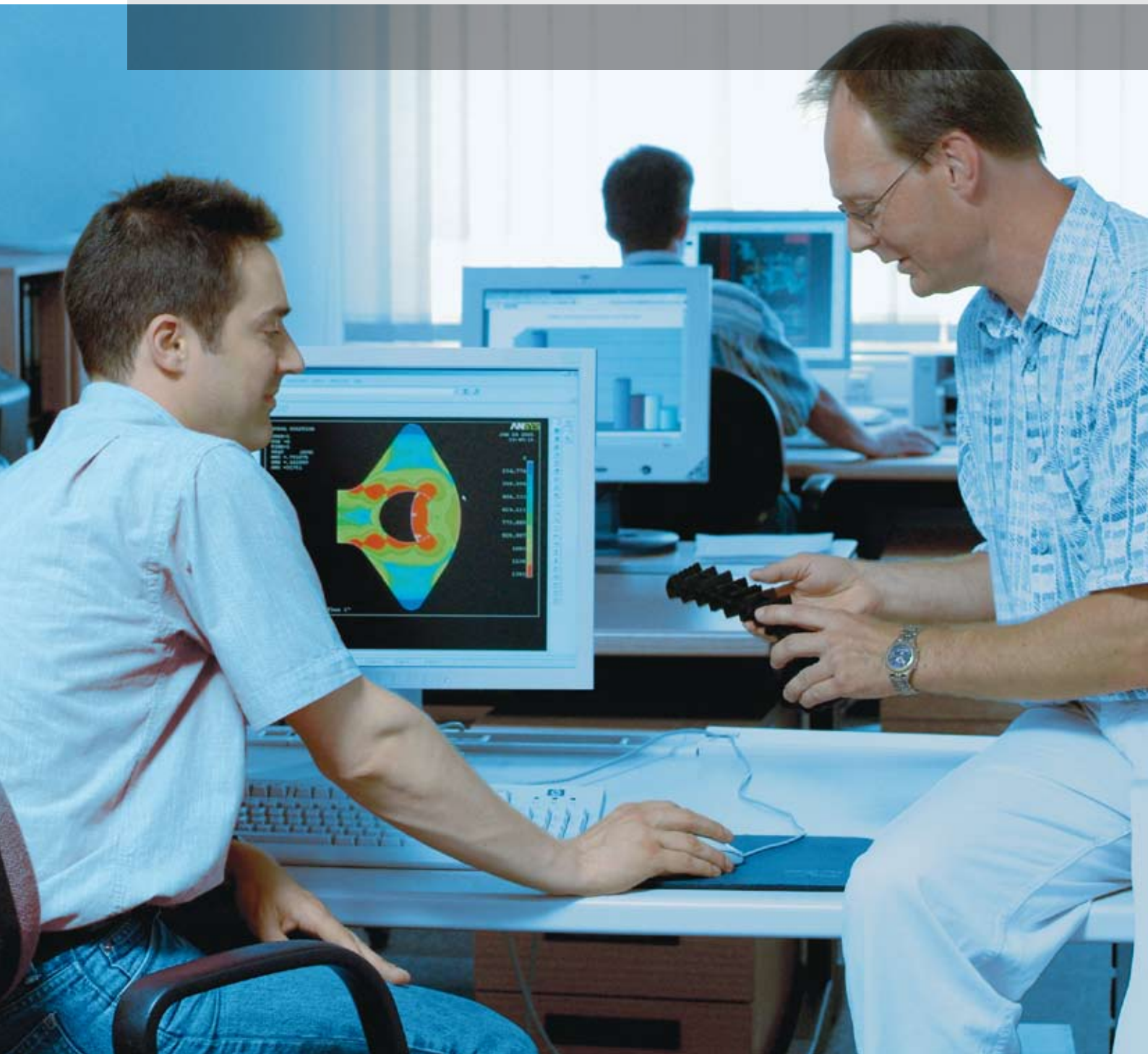

Inverted tooth chains for conveying:
The profitable solution for optimally implementing conveying applications safely and reliably.

Whether for heavy-duty, robust operation, or to convey parts with small or large dimensions, processed or unprocessed workpieces, or even fragile items: Rexroth inverted tooth conveyor chains guarantees trouble-free operation of your conveying system.

These factors are met through the following pre-requisites:

- Low-friction rolling pivot joint made from case hardened steel and exhibiting a high degree of efficiency, resistance to wear, and durability
- Inverted tooth chain link plates with FE-optimized outlines made from high resistance heat-treated steel
- Sprockets featuring hardened involute toothing for smooth, impact-free meshing and a long service life

When compared to other conveyor systems, the advantages shine through:

- Optimum use of space due to maximum versatility as a modular system
- **The proverbial quiet running; in a word: silent chain**
- Extremely long service life and availability
- High temperature resistance
- Highly robust and durable



Bosch Rexroth AG
Tooth Chain Drives
Zur Dessel 14
31028 Gronau (Leine), Germany
P.O. Box 12 55
31022 Gronau (Leine), Germany
Phone +49 5182 5870
Fax +49 5182 58730
toothchain@boschrexroth.de
www.boschrexroth.de

Argentina

Bosch Rexroth S.A.I.C.,
Carapachay, Buenos Aires
Phone +54 1 147560140
Fax +54 1 147560136

Australia

Bosch Rexroth PTY. Ltd.
Kings Park N.S.W.
Phone +61 2 98317788
Fax +61 2 98315553

Austria

Bosch Rexroth GmbH, Pasching
Phone +43 7221 6051321
Fax +43 7221 6051226

Belgium

Bosch Rexroth N.V., Bruxelles
Phone +32 2 4512667
Fax +32 2 4512789

Brazil

Bosch Rexroth Ltda., Atibaia-SP
Phone +55 11 44145832
Fax +55 11 44145713

Canada

Bosch Rexroth Canada Corp. Ontario
Phone +1 9 05 3355511
Fax +1 9 05 3354184

Czech Republic

Bosch Rexroth spol.s.r.o., Brno
Phone +420 5 48126355
Fax +420 5 48126354

Denmark

Bosch Rexroth A/S, Hvidovre
Phone +45 36 774466
Fax +45 36 770866

Finland

Kraftmek Oy, Helsinki
Phone +35 8 97557355
Fax +35 8 97550414

France

Defa S.A., Argenteuil
Phone +33 1 30259420
Fax +33 1 30259459

Great Britain

Bosch Rexroth Limited, Cirencester
Phone +44 1285 863000
Fax +44 1285 863030

Greece

Bosch Rexroth S.A., Athens
Phone +30 210 3411600
Fax +30 210 3422759

Hungary

Bosch Rexroth Kft., Budapest
Phone +36 14223200
Fax +36 14223201

Italy

Bosch Rexroth S.p.A., Cernusco
Phone +39 02 923651
Fax +39 02 92365500

Vibi S.p.A., Settimo Milanese

Phone +39 02 33502335
Fax +39 02 33502377

Japan

Mecman Japan Ltd., Saitama-Shi
Phone +81 48 8333111
Fax +81 48 8333123

Malaysia

Bosch Rexroth Sdn. Bhd., Shah Alam
Selangor
Phone +60 378 448000
Fax +60 378 454800

The Netherlands

Bosch Rexroth B.V., Boxtel
Phone +31 411 651951
Fax +31 411 651483

New Zealand

Bosch Rexroth Ltd., Auckland
Phone +64 9 2744172
Fax +64 9 2746477

Poland

Bosch Rexroth Sp.z.o.o., Pruszkow
Phone +48 22 7381870
Fax +48 22 7588735

Portugal

MFE Comercio Int. Lda., Marinha
Grande Cedex
Phone +351 244 575840
Fax +351 244 575849

Singapore

Bosch Rexroth Pte. Ltd., Singapore
Phone +65 68 61 2702
Fax +65 68 61 1825

Slovakia

TBH Technik s.r.o., Zilina
Phone +421 41 5079711
Fax +421 41 5079726

Slovenia

La & Co. d.o.o., Maribor
Phone +386 24292660
Fax +386 24205550

South Africa

Tectra Automation (Pty) Ltd.,
Endersvale
Phone +27 11 9719400
Fax +27 11 9719440

South Korea

Bosch Rexroth Korea Ltd., Busan
Phone +82 51 2600768
Fax +82 51 2668131

Spain

Bosch Rexroth S.L.,
Sta. Perpetua de Mogoda
Phone +34 93 7479500
Fax +34 93 7479401

Sweden

Bosch Rexroth AB, Stockholm
Phone +46 8 7279551
Fax +46 8 6476373

Switzerland

Bosch Rexroth Schweiz AG, Buttikon
Phone +41 32 6863928
Fax +41 32 6863936

Turkey

Bosch Rexroth Otomasyon, Istanbul
Phone +90 212 4111300
Fax +90 212 4111317

USA

Bosch Rexroth Corp., Lexington/KY
Phone +1 8 59 2813434
Fax +1 8 59 2813487

The data specified above only serve to describe the product. No statements concerning a certain condition or suitability for a certain application can be derived from our information. The given information does not release the user from the obligation of own judgement and verification. It must be remembered that our products are subject to a natural process of wear and aging.

© This document, as well as the data, specifications and other informations set forth in it, are the exclusive property of Bosch Rexroth AG. Without their consent it may not be reproduced or given to third parties.

Subject to modification.
Printed in Germany.
Order no.
8865000083/2009-04/EN